



1928

K.N. Toosi University of Technology

# PIPRO

Petroleum Industry Productivity Research Center



[www.PIPRC.kntu.ac.ir](http://www.PIPRC.kntu.ac.ir)

**PIPRC** Petroleum Industry Productivity Research Center

K.N. Toosi University of Technology.

Iran, Tehran Province, Tehran, Mirdamad Blvd, No. 470

Tel: +98(21)88881002, Fax: +98(21)88462066

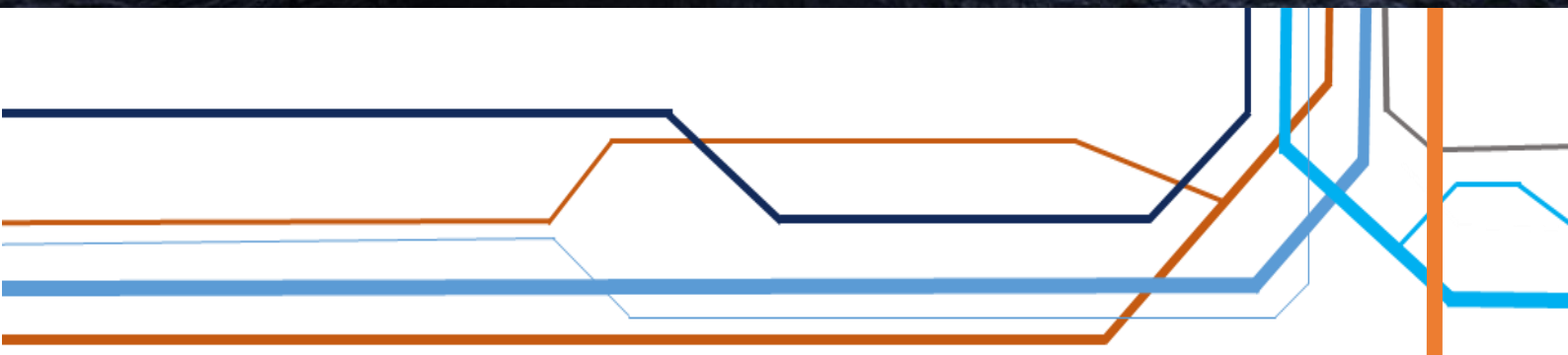

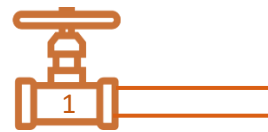

## Table of Contents

Mission of the Petroleum Industry Productivity Research Center .....	2
PART I: Research Groups.....	3
The Exploration and Optimal Development of Oil and Gas Reservoirs Research Group.....	4
The Energy and Environment Research Group.....	5
The Oil, Gas and Petrochemical Processing Research Group .....	6
PART II: Projects .....	7
PART III: Faculty Members .....	48





## Mission of the Petroleum Industry Productivity Research Center

Petroleum has been the leading industry worldwide for more than 100 years. Any improvement in oil and gas production and consumption will have a significant effect on other industries and our lives at large. With the aim of improving quality and quantity within the Iranian petroleum industry, the Petroleum Industry Productivity Research Centre (PIPRC) has been established at the K.N. Toosi University of Technology (KNTU). KNTU is a leading university in industrial research and development. With more than 80 years of experience in engineering education, research and industrial connections, KNTU has established a close relationship with the petroleum industry. Relying on extensive experience in the oil and gas industry, the PIPRC aims to further improve advanced applied research within KNTU and to extend the university's role in the petroleum industry.

The following areas are within the interest of the PIPRC:

- Examining the geoscience and geomatics of oil and gas reservoirs to improve oil processing
- Considering the chemical properties of produced oil and gas to enhance downstream processing
- Implementing geomechanical modeling of oil and gas reservoirs
- Conducting data mining and designing advanced control and automation systems
- Researching the environmental impact of the petroleum industry
- Utilizing greener EOR/IOR technologies.

The PIPRC engages distinguished professors and researchers from various departments of KNTU, including geomatics and geoscience, civil engineering, mechanical engineering, electrical engineering, computer engineering, chemistry, mathematics, and physics. Many renowned petroleum industry experts are adjunct members of the PIPRC, and close relations are maintained with both domestic and international companies in the petroleum industry. Consequently, the PIPRC has become a leading research center in the petroleum industry, with the capability of supplying advanced research and solutions.



# PART I: Research Groups



## The Exploration and Optimal Development of Oil and Gas Reservoirs Research Group

The Exploration and Optimal Development of Oil and Gas Reservoirs (EODR) research group focuses on the exploration program and static/dynamic reservoir analysis and code development. The EODR research group aims to design and implement a GIS-based model to determine high-potential areas for hydrocarbon reservoirs and to provide multiscale and coupled models for analyzing rock, pores and fluids from diverse sources, with various scales from micro to mega. Thanks to a multidisciplinary set of

scientists, with backgrounds in civil, mechanical, electrical, geomatics and environmental engineering as well as chemistry, the EODR research group specializes in the management of mature oil and gas fields and the development of new fields, while concentrating on the big picture and integrated modeling of the reservoir. The EODR research group has a keen interest in intelligent completions, including local or remote monitoring, evaluating and actively managing production or injection in real time without any good interventions.

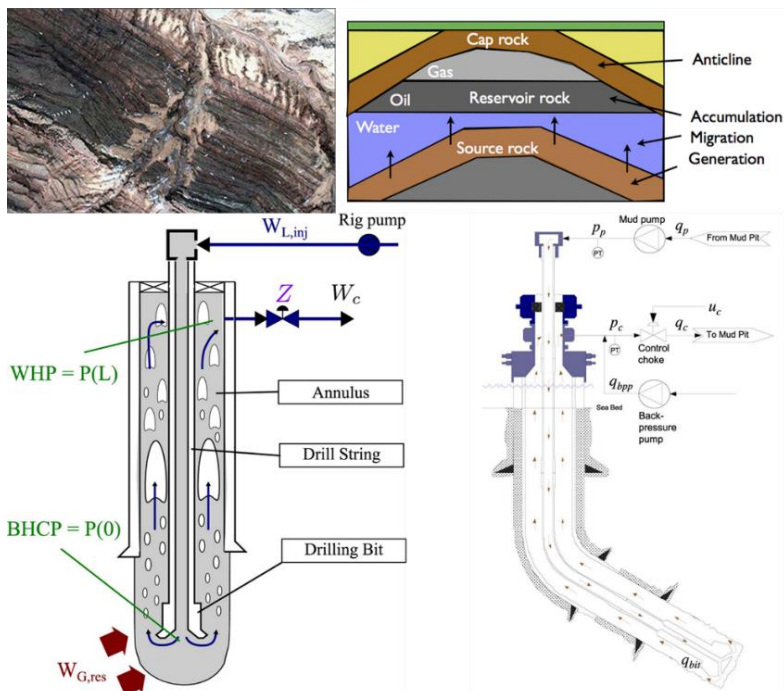



## The Energy and Environment Research Group

The Energy and Environment (E&E) research group focuses on increasing the efficiency of the production and consumption of the oil and gas sector while keeping the environment cleaner. In addition to valuable equipment, the group takes advantage of a multidisciplinary set of scientists with a wide range of expertise, including mechanical engineering, electrical engineering, geomatics engineering and chemistry. The first objective of the group is to increase energy efficiency through tested industrial solutions. The energy efficiency measures designed by the group are for both upstream and downstream usage.

Highly volatile oil prices make it necessary to assure the lowest possible operational energy costs for the extracted oil or gas. We also offer solutions for aging oil and gas wells, with the objective to decrease the cost of oil and gas extraction. The second aim of the group is to offer environmental solutions for the oil and gas sector. The group members have a wide range of innovative measures to monitor and reduce emissions and to maintain cleaner fossil fuel production and consumption. We also have strong track records of successful industrial projects, in addition to publications in highly reputable international journals.





## The Oil, Gas and Petrochemical Processing Research Group

**T**he Oil, Gas and Petrochemicals Processing (OGPP) research group focuses on the systematic study of oil extracted from the country's oil fields and the evaluation of products that may be extracted and processed, taking into account economic considerations and the variety of technical knowledge available in the country. The OGPP also provides consultancy services to oil field equipment designers to ensure the construction of stable and suitable equipment that will be in contact with oil

compounds. Another objective of this group is the development of new methods for optimizing the processing of oil, gas and petrochemicals with regard to considerations of petroleum compounds. This research group has a keen interest in the design and construction of advanced control and monitoring systems in the production processes of petroleum products, as well as the analysis of petroleum industry data and metadata for optimizing the process of oil and gas production.





## PART II: Projects







## Supervisor of Iranian National Intelligent Pipeline Instrumentation Gauges (PIG)

**Client:** National Iranian Gas Company (NIGC)

**Date:** 2015

**Director project:** Dr. Hamid D. Taghirad

**Project associate members:** Dr. Ahmad Reza Tahsiri, Dr. Mohammad Ali Nekouei, Dr. S. Ali A. Moosavian, Dr. Ali Ghaffari.

**Project type:** Supervision

**Project collaborator:** K.N. Tossi University of Technology (KNTU) & Segal Pardazesh Engineering Company

### Summary of project:

**P**igging in the context of pipelines refers to the practice of using devices known as Pipeline Instrumentation Gauges "PIG" to perform various maintenance operations. This is done without stopping the flow of the product in the pipeline. These operations include but are not limited to cleaning and inspecting the pipeline. Pigging has been used for many years to clean large diameter pipelines in the oil industry. Today, however, the use of smaller diameter pigging systems is now increasing in many continuous and batch process plants as plant operators search for increased efficiency and reduced costs. There are four main uses for pigs:

- Physical separation between different fluids flowing through the pipeline

- Internal cleaning of pipelines
- Inspection of the condition of pipeline walls (also known as an Inline Inspection (ILI) tool)
- Capturing and recording geometric information relating to pipelines (e.g., size, position).

Since April 2015, Aras Intelligent PIG Research Group has started a collaboration with research and development department of National Iranian Gas Company (NIGC) as the supervisor of Iranian national intelligent PIG project. This project is one of the ten crucial national projects that Iranian Oil ministry has focused on. Segal Tech Company is the engineering and procurement party of the project which has to design, supply all equipment and integrate them to provide three types of intelligent PIG namely High-Resolution MFL, High-Resolution TFI, and the Calliper.

Each of these intelligent PIGs consists of several major subsystems such as electronic and mechanical, signal processing and software for displaying the pipeline defects. Aras Intelligent PIG Research Group closely monitor and control the progression of this national

project, as well as provides technical consultations to Segal Tech. The project has accomplished its design, manufacturing, assembly and pull through tests so far, and is in its final stage of approval.

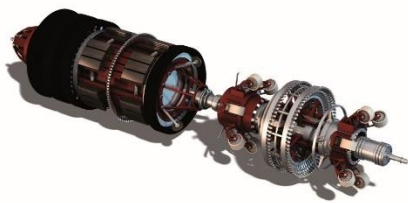

A typical Intelligent PIG device



Iranian National MFL PIG



Iranian National TFI PIG



Iranian National Calliper (EGP) PIG

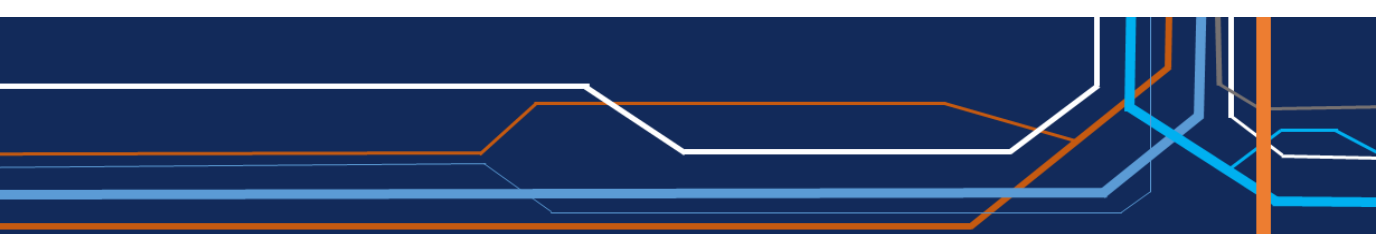

## Development and design of spatial data infrastructure of Iranian Gas Transmission Company

**Client:** Iranian Gas Transmission Company

**Date:** 2010-2011

**Director project:** Dr. Mohammad Karimi and Dr. Ali Mansourian

**Project associate members:** Dr. Mohammad Javad Valadan Zoej, Dr. Hamid Ebadi, and Dr. Mohammad Taleai

**Project type:** Feasibility study and design

**Project collaborator:** K.N. Tossi University of Technology (KNTU)

### Summary of project:

The Iranian Gas Transmission Company (IGTC) signed a contract with K N Toosi University of Technology to perform a research project on the development and design of Spatial Data Infrastructure (SDI) for IGTC. In this project, after giving a comprehensive description about the current status of the central department of IGTC and some of the regional operational branches, from organizational duties, spatial and attribute data, technological information, and their human resources

perspectives the existing status of the company from SDI point of view was analyzed and summarized. The major outputs of this projects are includes:

- Assessment and Requirement Analysis
- Conceptual model and Standard of Spatial Database
- Metadata standard for spatial database
- Operational routines for spatial data management

Definition of requirement projects and activities for GIS and SDI.

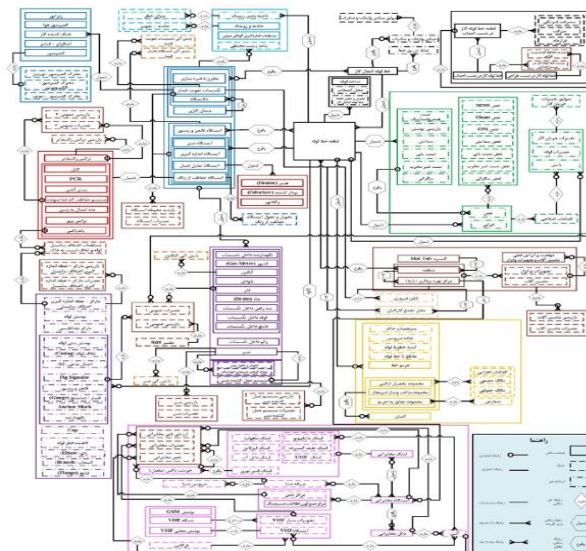

## Hydrocarbon resources potential mapping using geographic information system (GIS)

**Client:** National Iranian Oil Company

**Date:** 2014-2015

**Director project:** Dr. Mohammad Karimi

**Project associate members:** Dr. Abbas Alimohammadi and Mohammad Arab Amiri

**Project type:** Design and Implementation

**Project collaborator:** K.N. Tossi University of Technology (KNTU)

### Summary of project:

The main objective of this project is to design and implement a GIS-based model to determine the high potential areas for hydrocarbon reserves for further exploration work, including seismic surveys and exploration drilling. In this project, a data-driven approach, evidential belief function, were used to implement the model. A case study in Ahvaz/Khuzestan province, south-west of Iran, is proposed to assess the feasibility of this modeling

technique. Factors associated with hydrocarbon resources were assembled in a spatial database and a hydrocarbon resource potential map was created using the evidential belief function model. The method quantifies the spatial relationship between input data and the petroleum resources. This allows the exploration manager to identify those data themes that are the best predictors of petroleum prospects.

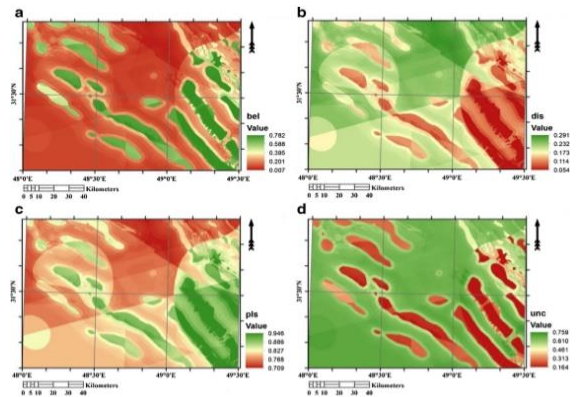
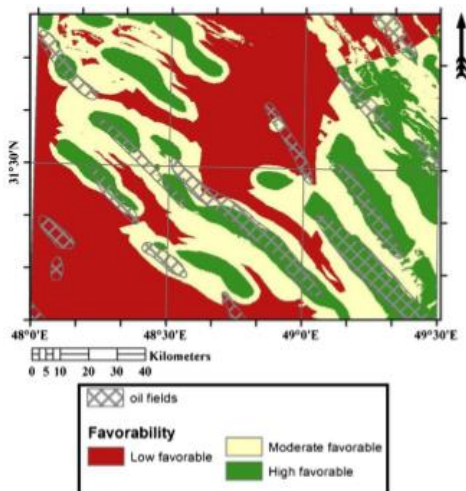

## Development, design and implementation of an integrated performance monitoring and fault detection system for gas turbines

Client: National Iranian Gas Company

Date: 2008-2013

Director project: Dr. Ali Khaki-Sedigh

Project type: Industrial Implementation

Project collaborator: K.N. Tossi University of Technology (KNTU) & Tourbotec Company (<http://turbotec-co.com/>)

### Summary of project:

**D**ue to the strategic role of efficient and reliable energy production, the Iranian National Gas Company delineated and signed a contract with K N Toosi University of Technology to perform a research project on the development, design and implementation of an integrated performance monitoring and fault detection system for GT10B gas turbines

and Demag Delval compressors. The key objectives of the project include:

- Development of theoretical knowledge of an integrated performance monitoring and fault detection system for gas turbines.
- Software and hardware development and online implementation of the designed integrated system in GT10B gas turbines in Qom power plant.

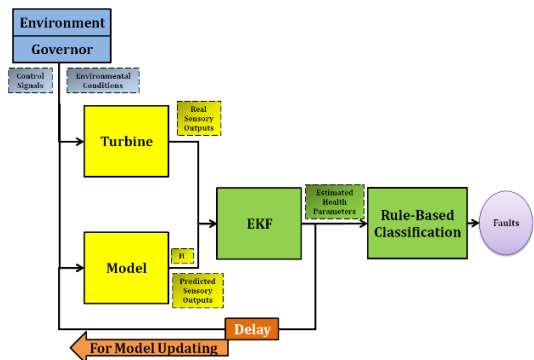
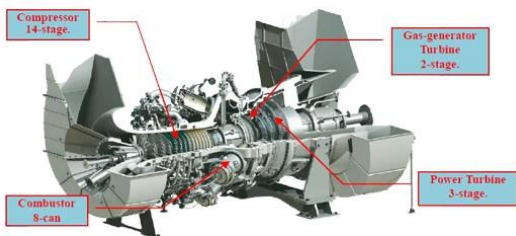

## Design and implementation of Universal Control System (UCS)

**Client:** High-Tech Bureau of the Ministry of Industry

**Date:** 2005-2008

**Director project:** Dr. Ali Khaki-Sedigh

**Project associate members:** Dr. Alireza Fatehi

**Project type:** Design, Development and Pilot Plant Implementation

**Project collaborator:** K.N. Tossi University of Technology (KNTU)

### Summary of project:

Nowadays, Advanced Process Control (APC) systems are widely used in industry. However, the main challenge on the application of APC systems is tuning of their parameters, including model structure like model order, delay and model parameters, controller structure and parameters like control and prediction horizon in model predictive controllers, noise filters and so on. Practically, an APC expert should decide on them through some experimental test on the site. Every re-tuning of the controller also needs the presence of experts. This increases the commissioning and operational costs of APC, one of the main reasons that many industries avoid

using APC systems. By UCS, we developed an APC that only needs some operational available information, like the tag number of MV and CV, acceptable setpoint and MV step changes and so on. This makes the APC design a kind of plug-and-play procedure that can be handled by in residence automation engineers at the plant site. Both PID and APC controllers are automatically designed through some carefully, yet universally, step by step experiments. UCS has already been tested on some process systems, including level, flow, temperature, pressure and pH neutralization pilot plants.

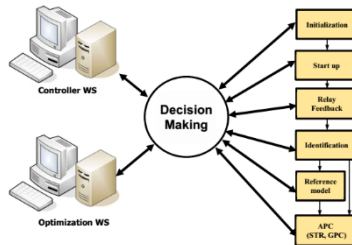
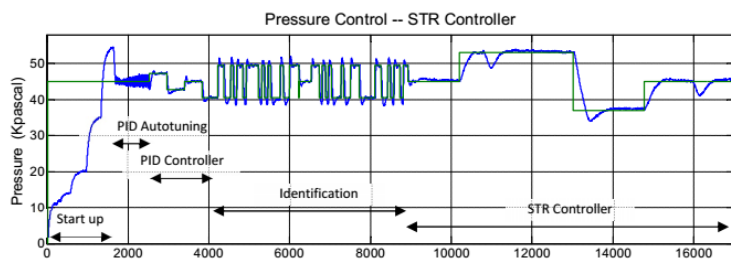



## Degradation of textile dyes and 2, 6-dimethylphenol in the presence of manganese (III) porphyrin supported onto multi-walled carbon nanotubes

Date: 2014-2016

Director project: Dr. Saeed Rayati

Project type: {Feasibility/Simulation study, Laboratory/Pilot Plant Implementation, Industrial Implementation, Engineering, Procurement, Construction, Installation, Commissioning, Other (please name)}

Project collaborator: K.N. Tossi University of Technology (KNTU)

### Summary of project:

A manganese porphyrin supported onto multi-walled carbon nanotubes (Mn(TCPP)OAc@MWCNT) The heterogeneous catalyst was characterized by powder X-ray diffraction, FT-IR, atomic absorption and UV-vis spectroscopy, field emission scanning electron microscopy (FE-SEM) and also thermogravimetric analysis (TGA). The TGA curve shows that the nanocatalyst was thermally stable up to almost 350°C. This catalyst was found to be able to oxidize different synthetic textile dyes in aqueous media over a wide pH range at ambient temperature

with *tert*-butyl hydroperoxide (TBHP) as the oxidant. The influence of some important parameters such as initial pH of the dye solution, temperature, and concentration of the catalyst, oxidant, and co-catalyst was inspected. Also, the ability of this heterogeneous catalyst in the oxidation of 2,6-dimethylphenol (with excellent selectivity for quinone (86%)) with TBHP in acetonitrile was evaluated. The separation and recycling of the catalyst are simple and catalyst can be used several successive cycles without a significant decrease in catalytic activity.

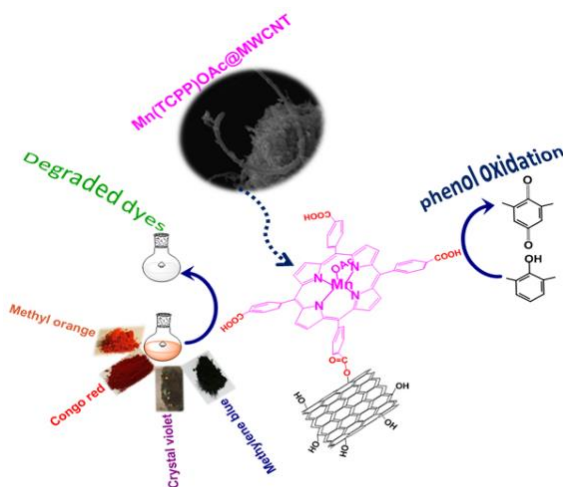

## Aerobic oxidations of sulfides and alkenes over Fe-porphyrin supported onto multiwall carbon nanotubes as a model of P450 enzyme

Date: 2014-2017

Director project: Dr. Saeed Rayati

Project type: Laboratory experiment

Project collaborator: K.N. Toosi University of Technology (KNTU)

### Summary of project:

Aerobic oxidation of various olefins and sulfides were reported in the presence of Fe-porphyrin supported onto functionalized multi-wall carbon nanotubes. High yield of

products, excellent selectivity, short reaction time, mild conditions, and excellent reusability of the catalyst are of advantages of this catalytic system.

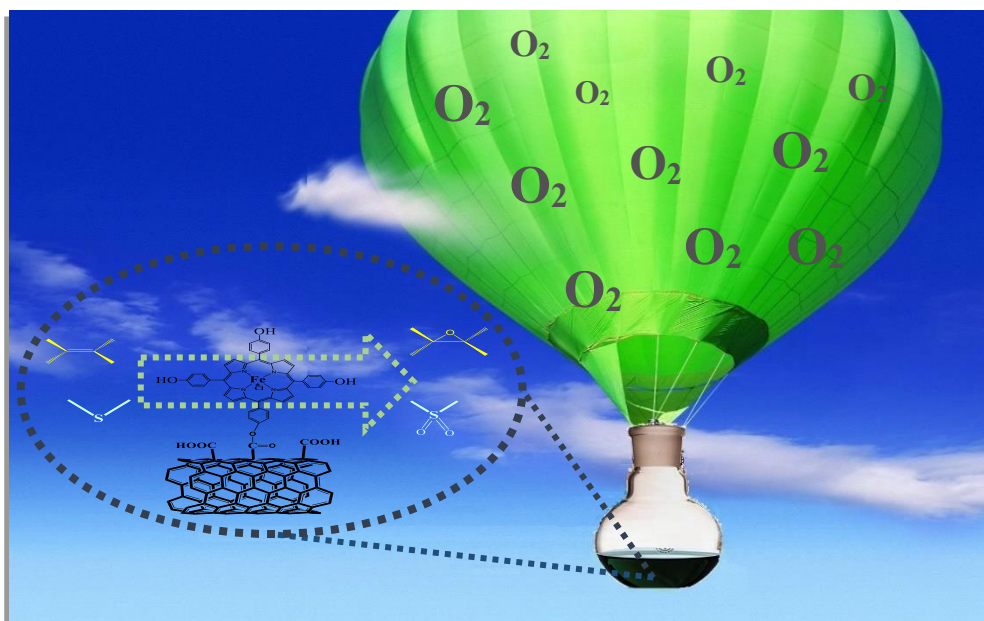

## Data Reconciliation and Gross Error Detection of a Refinery Process

**Client:** Research Institute of Petroleum Industry

**Date:** 2009-2010

**Director project:** Dr. Babak Tavassoli

**Project type:** Simulation study

**Project collaborator:** K.N. Tossi University of Technology (KNTU)

### Summary of project:

This project was a part of a larger collaborative research on real-time optimization (RTO) of a Hydrodesulphurization (HDS) plant. An RTO system optimized the plant performance by adjusting the setpoints of the closed loop controller in real-time, i.e. during the operation of the plant. For this purpose, it is required to provide high-quality data for the online model-

based optimization. A way of improving the measurement quality is a correction of the measurement errors based on the available physical model of the plant. This process is known as model-based data reconciliation. Additionally, the plant model can be used to detect gross errors (large errors due to measurement failures).

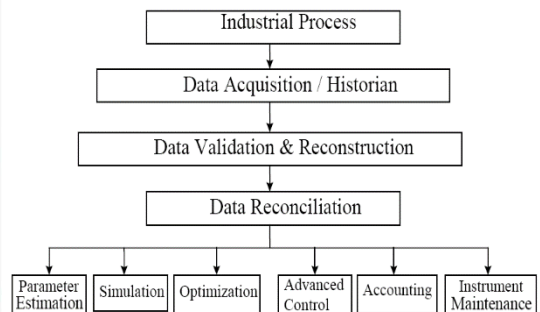
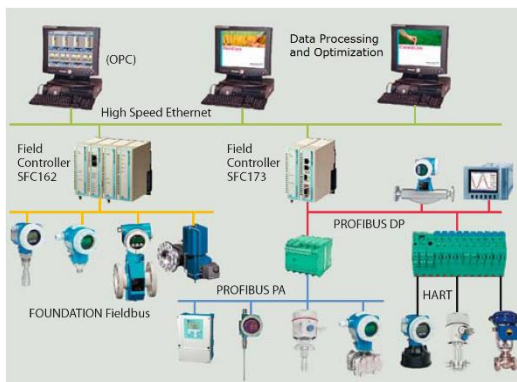

## Control of Process Trajectory for avoiding failures and operational constraints

**Client:** Research Institute of Petroleum Industry

**Date:** 2009-2010

**Director project:** Dr. Babak Tavassoli

**Project type:** Simulation study

**Project collaborator:** K.N. Tossi University of Technology (KNTU)

### Summary of project:

This project was a part of a larger collaborative research on real-time optimization (RTO) of a Hydrodesulphurization (HDS) plant which is normally cascaded with the control system. An RTO system optimizes the plant performance by adjusting the setpoints of the closed loop controller in

real-time, i.e. during the operation of the plant. To achieve the benefits of the RTO system it is required that the control system provides an acceptable performance to eliminate oscillations and transient errors as much as possible. In this project, the model predictive control algorithm was utilized for this purpose.

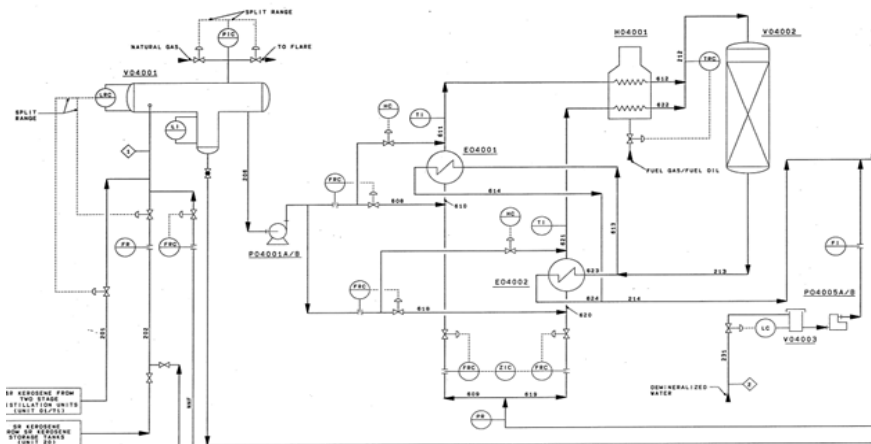

## Integrating GIS and other practical software in Iranian Gas Transportation Company: Basic study

**Client:** Iranian Gas Transmission Company

**Date:** 2010-2011

**Director project:** Dr. Mohammad Taleai

**Project associate members:** Dr. Mohammad Karimi, Dr. Mohammad Javad Valadan Zoej, and Dr. Hamid Ebadi

**Project type:** Feasibility study and design

**Project collaborator:** K.N. Tossi University of Technology (KNTU)

### Summary of project:

The Iranian Gas Transmission Company (IGTC) signed a contract with K N Toosi University of Technology to perform a research project on the integrating geographic information system (GIS) and other practical software in Iranian Gas Transportation Company. In this project, a comprehensive description of current systems and databases in IGTC which

were related to GIS and spatial database were analyzed and summarized. The major outputs of this projects are includes:

- Definition of the mission, vision, and objectives of IGTC GIS
- Design of the architect of IGTC GIS
- Design of the architect of the integrating GIS, PIMS and CMMS systems in IGTC

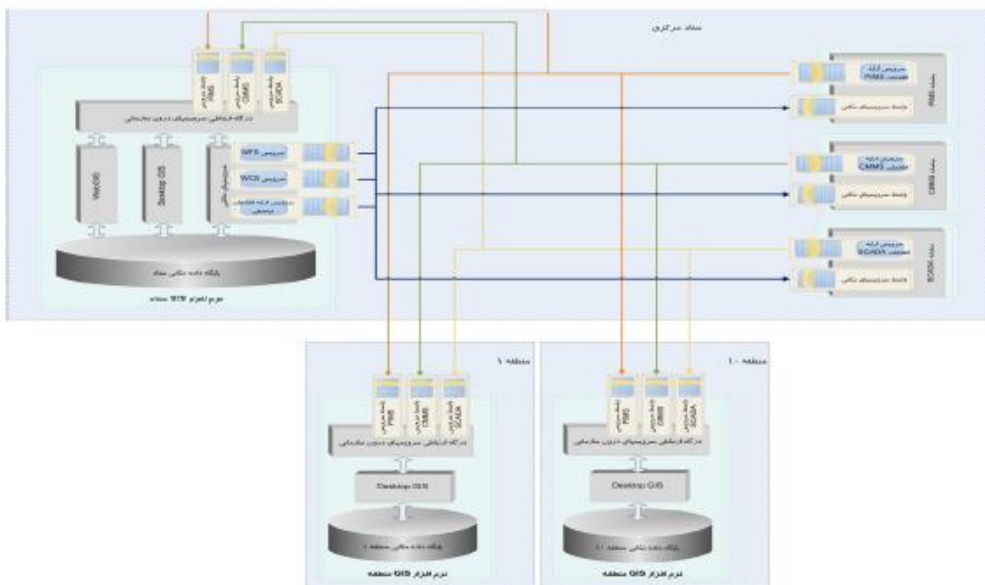

## Risk Assessment of Transmission Gas Pipeline with Use of Spatial Analysis

Client: Iranian Gas Transmission Company

Date: 2015-2016

Director project: Dr. Mohammad Karimi

Project type: Design and Implementation

Project collaborator: K.N. Tossi University of Technology (KNTU)

### Summary of project:

The purpose of this study is to compute the risk of transmission gas pipeline, so GIS is used as a decision-making tool for the analysis of the pipeline and its surrounding environment and overlapping of factors and using of GIS analysis is provided. In this project, both indexing system and probabilistic risk assessment were implemented on sweet and sour gas pipeline with a length of 40 km in Bushehr Province. In indexing system

method, the lowest rating of the relative risk related to sour gas pipeline with the range of 3-11. In a probabilistic method, the highest amount of risk is associated with the sour gas pipeline in the range of 0 to  $1E-04 < IR < 2E-04$ . Thus, creating a general framework of risk assessment in GIS platform is very functional to improve communication and cooperation between authorities, planners, and experts, in order to prevent and reduce damage accidents.

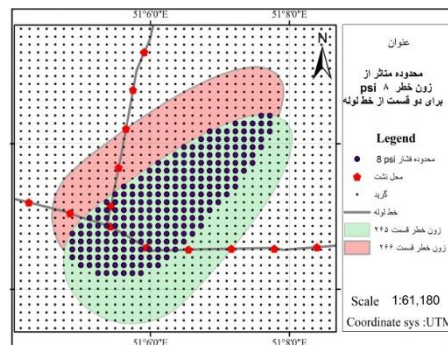
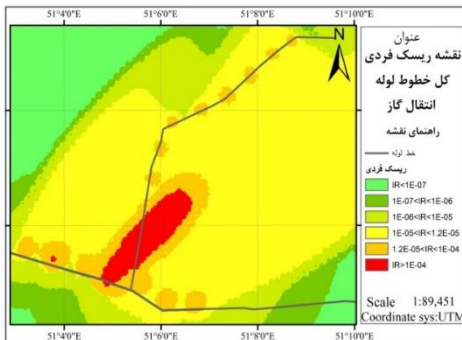





## Gas Desulfurization for 1000 MWth Shahid Rajaei Powerplant

**Client:** Shahid Rajaei utility company, Iran

**Date:** 2015-2017

**Director project:** Dr. Sadegh Seddighi

**Project associate members:** Dr. Sadegh Seddighi

**Project type:** Engineering, Pilot Plant Building

**Project collaborator:** K.N. Tosi University of Technology (KNTU)

### Summary of project:

This project successfully designed and carried out the optimum desulfurization method for the Shahid Rajaei power plant. Sulfur emissions are proved to be among the most hazardous emissions from the fossil fuel leading to various human diseases and respiratory illnesses and acid rains. Shahid Rajaei power plant ordered this project in order to reduce its

sulfur emission using new engineering methods. Various desulfurization methods were designed for the client and finally, the economically optimum method is selected for the pilot unit capable of reducing the power plant sulfur emission to the new environmental protection agency standards.

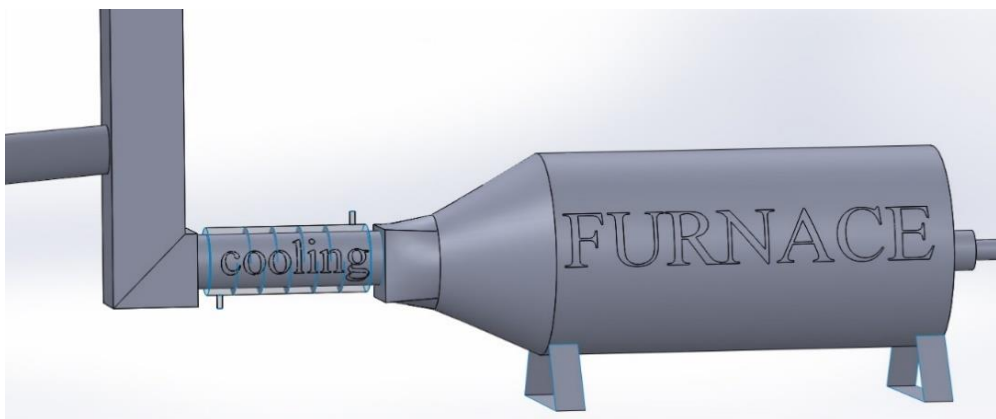

## Model Predictive Control of a Gas Refinery Boiler

**Client:** Bidboland Gas Refinery

**Date:** 2012-2013

**Director project:** Dr. Babak Tavassoli

**Project type:** Simulation study

**Project collaborator:** K.N. Tossi University of Technology (KNTU)

### Summary of project:

In the gas refinement process, the required steam refinement unit is supplied by a boiler. A boiler system is a nonlinear and multivariable system involving several interacting control loops. In this process, the PID controller is normally used to control the pressure and liquid level of the vessel. However, it is not easy to achieve an acceptable performance with PID loops and avoid fluctuations. An improved control algorithm for replacing the PID controllers is the model predictive control algorithm. This algorithm has a

high computational load which can be reduced by applying the multi-parametric MPC control. Based on this, the boiler controller in the gas refinement unit is studied and a nonlinear model of the boiler has been obtained and validated using the data obtained from experiments at steady state. Then, the multi-parameter explicit predictive controller has been used to control the level and the pressure of the boiler. It is shown that the controller performance improves considerably.

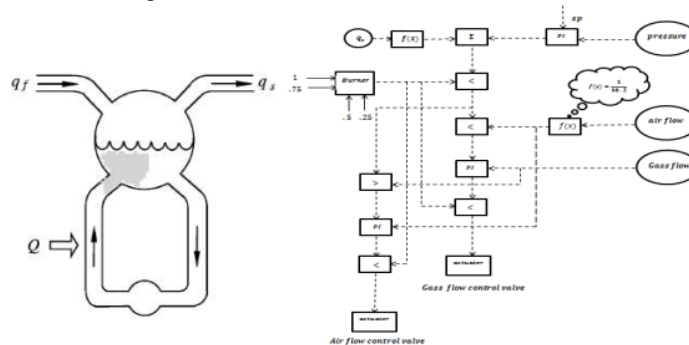

## Advanced process control (APC) system for pH neutralization plant based on multiple model controller

Client: National Iranian Oil Refinery & Distribution Company (NIORDC)

Date: 2010-2011

Director project: Dr. Alireza Fatehi

Project associate members: Dr. Ali Khaki-Sedigh

Project type: Design, Development and Pilot Plant Implementation

Project collaborator: K.N. Tossi University of Technology (KNTU)

### Summary of project:

Without a proper control system, the production in any process plants, including refinery plants, cannot reach to technically high quality and economically compatible level. Therefore, any refinery plant needs an advanced process control (APC) beside its advanced automation system. However, conventional APC may be so complex that they cannot be practically operable in every process plants. In this project, a new configuration of APC is proposed for

refinery plants. The controller is based on multiple model controller, in which simple linear controllers are designed for some operating points of the process. A careful, but transparent, supervisory algorithm selects each controller at any operating point. This reduces the complexity of the control system, while keeps the overall quality in high level. The controller has been experimentally tested on a pH neutralization pilot plant.

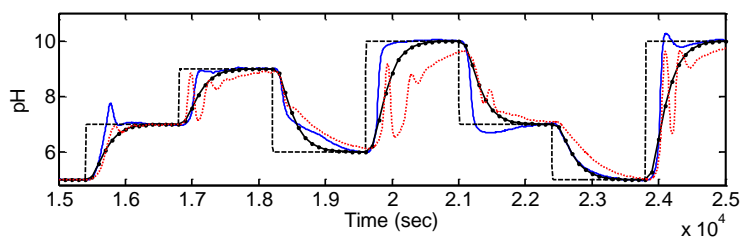
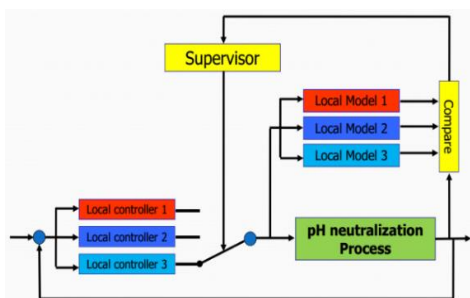

Experimental result on pH neutralization plant  
 Black: desired pH, Blue: Proposed Multiple APC, Red: Conventional adaptive APC

## Design and Construction of a Tele-operated (Melon) and an autonomous (Silver) robots

**Client:** National Iranian Oil Company (NIOC)

**Date:** 2006-2010

**Director project:** Dr. Alireza Fatehi

**Project associate members:** Dr. Hamid Taghirad, Dr. Ali Mousavian

**Project type:** Design, Development and Robot Construction

**Project collaborator:** K.N. Toosi University of Technology (KNTU)

### Summary of project:

Oil fields exploration and pipeline investigation are among top priority tasks in the oil industry. However, due to a vast area of exploration and hazardous nature of the oil fields, it is a difficult and dangerous duty. Nowadays, exploring robots become popular on investigating the hazardous plain area. To develop the technology of mobile robots with the capability of maneuvering in the oilfields

and across the pipelines, two robots have developed in this project. The melon robot is designed to explore plain areas using autonomous technology without human interference, while Silver robot, by using teleoperation technology, has the ability to explore not only plain areas but also can climb hills and stairs and pass some obstacles like woods and small rocks.



Silver Teleoperated Robot

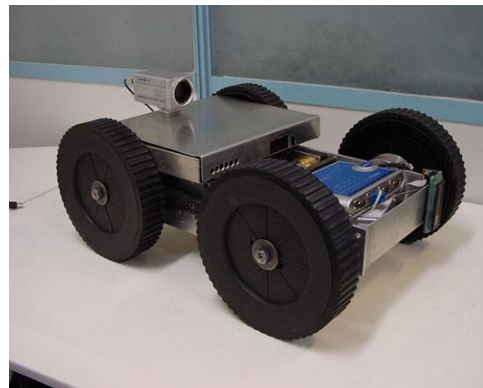

Melon Autonomous Robot

## Feasibility study of advanced process control (APC) system in refinery plants

**Client:** National Iranian Oil Refinery & Distribution Company (NIORDC)

**Date:** 2009-2010

**Director project:** Dr. Ali Khaki-Sedigh

**Project associate members:** Dr. Alireza Fatehi

**Project type:** Feasibility study

**Project collaborator:** K.N. Toosi University of Technology (KNTU)

### Summary of project:

Advanced Process Control (APC) becomes the main part of any modern refinery plants of major oil production companies like BP, Shell, Chevron and so on. APC, like model predictive control (MPC), is an advanced control algorithm to manipulate the actuators in order to reach reliable and sustainable production. APC is widely used by control and automation provider companies like Honeywell, Yokogawa, AspenTech and so on, to

control different units of the refineries worldwide, like in distillation column, Fluid Catalytic Cracking (FCC) units. In this project, latest production and application of APC technologies by major control and automation companies have been studied. All the companies on the vendor list of NIORDC were investigated for any APC production. In addition, the applicability of different control algorithms is studied in the APC products of refinery industry.

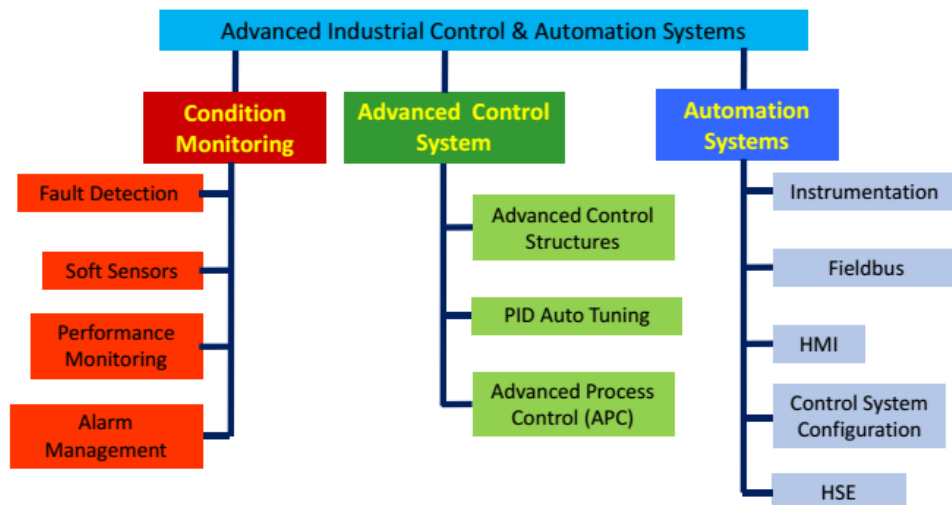

## A comprehensive and sustainable program for production, supply and demand management of oil and natural gas products in Iran until 1404

**Client:** National Iranian Oil Products Distribution Company

**Date:** 2009

**Director project:** Professor Majid Amidpour

**Project type:** Feasibility/Simulation study

**Project collaborator:** K.N. Toosi University of Technology (KNTU)

### Summary of project:

In this project, the prospect of oil products in Iran, as well as the prospect of the National Company for Distribution of the Oil Products, are carefully investigated and analyzed in terms of market volume, required capacity building, environmental impacts of activities and development of company activities using the integrated model made in LEAP software. The report is designed as abstract. Due to the fact that most outputs are available in the model and also the model has been completed and approved in provincial dimension, so it's possible to benefit from the results in the model environment. In general, the report presented in this section can serve as a background and context for future development scientific planning and

position of company in the prospect. The developed model has the ability to accurately reflect the realities by calibrating and appropriate changing in each year, and, if used, can increase the accuracy of predictions by covering the likelihood of an unexpected event occurring in the future. The results are presented in three scenarios: high, middle, and bottom, which respectively indicate the reference scenario as a reflection scenario of the current technology trend and factors affecting the energy system, the scenario of implementing energy saving strategies, as well as the scenario for concurrent implementation of precious and non-precious tools for integrated management of energy system.

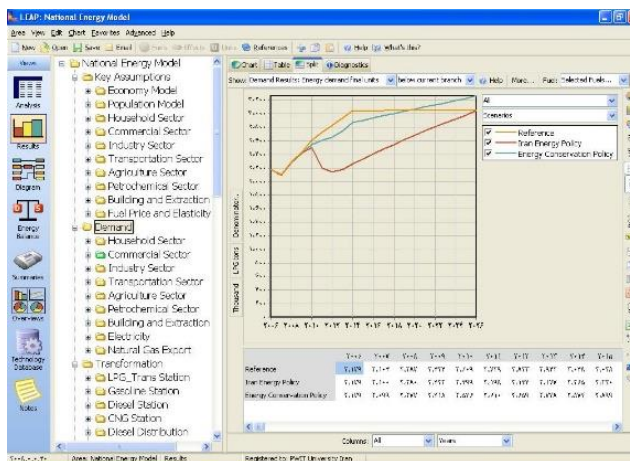



## Compilation of fuel basket and fleet of light vehicles

**Client:** Iran Fuel Conservation Company

**Date:** 2010

**Director project:** Professor Majid Amidpour

**Project type:** Feasibility/Simulation study

**Project collaborator:** K.N. Toosi University of Technology (KNTU)

### Summary of project:

The fleet fuel basket and fuel of light vehicles has been prepared by the National Oil Products Distribution Company and in close cooperation with the Fuel Consumption Optimization Company. On the other hand, it should be said that a special model has been designed and implemented apart from the integrated model for the development of a lightweight vehicles fuel basket of the country. This means that the fuel basket model is only a very small part of the integrated energy supply and demand model and has a special application that has been modeled on the transportation sector of the country at the national level. Due to the sensitivity and importance of planning and policy making for the supply of fuel in the light transportation sector and the optimal supply of portfolio combinations in recent years, as well as the need for careful monitoring of some CNG fuel, the

National Oil Distribution Company applied changes in fuel basket and lightweight fleet due to the accelerated development of parameters such as regional fuel prices, infrastructure development costs and the addition of vans in cooperation with the company, which the modeling has been done by eliminating the model weaknesses and improving edition. It should be noted that the results were signed by the members of the previous LEAP team through the software at the end of spring, and the final approval of the respectable Minister of Oil has been reached as a national document. The model is based on the maximization of social benefits and also on the basis of the limitations and views of the leaders, experts, and high objectives of the Islamic Republic of Iran. In general, the document's formation space has been within the framework of the following main plans and policies.

- Diversification into fuel and technology in the transport sector of the country
- Implementation of lightweight vehicles fuel consumption standards
- Implementation of the law on targeting the energy subsidies of the country
- Implementation of the Law on Public Transport Development and Fuel Management
- Removing the Workshop Conversion of Gas Vehicles and Moving to Gas-Based vehicles
- Considering environmental costs in the supply and demand chain
- Sustainable fuel supply in the transport sector
- Gradual elimination of import tariffs and the maintenance of 1.2 million light-weight production capacity in the country
- Development of simple, plug and electrical hybrid vehicles in the coming years

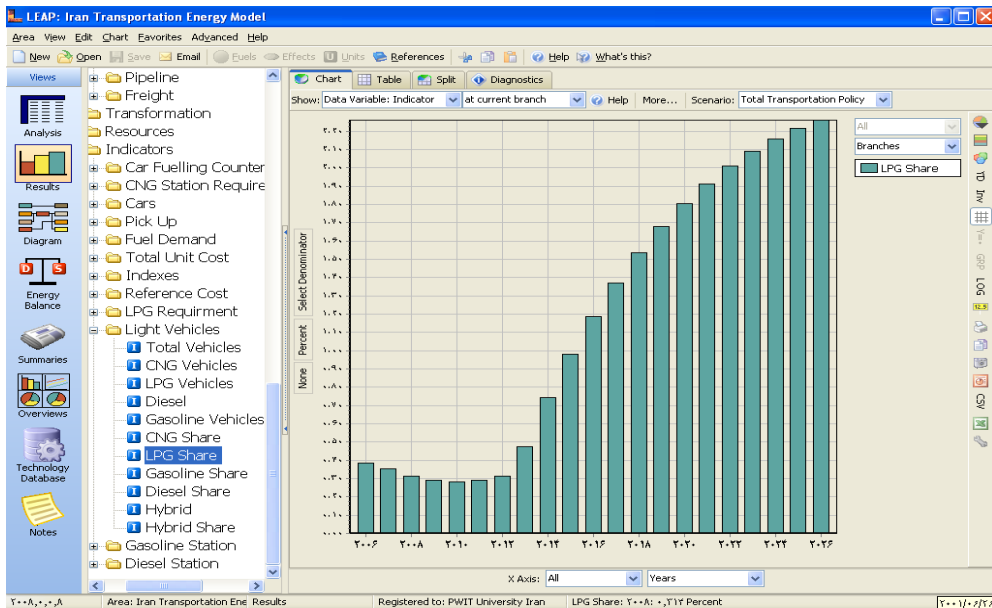

## Analysis of the status of energy and electricity carriers, gas and oil products in selected villages of the Iran

**Client:** National Iranian Gas Company

**Date:** 2009

**Director project:** Professor Majid Amidpour

**Project type:** Feasibility/Simulation study

**Project collaborator:** K.N. Toosi University of Technology (KNTU)

### Summary of project:

In this study, after a quick look at the basic concepts of energy, the state of consumption of energy carriers in households and in particular the state of consumption of energy carriers in the villages of the country has been examined. After calculating the per capita of rural population, the electric equivalents of household consumptions were determined and then, by examining the current per capita consumption of electricity and current power of the Ministry of Energy, the priority has been selected to replace the oil products with electricity. Then, the effects of this practice have been evaluated from the viewpoint of the involved enterprises (ministry of energy, oil, households and producer factories). Finally, the only heating and cooking energy supply in the rural part of four provinces of Khuzestan, Sistan and Baluchestan, Bushehr and Hormozgan, due to the strong transmission and distribution capacity against strong loads, as well as the low heating rate of these provinces compared with other

provinces, were identified as the villages of selected provinces. On the other hand, in order to prioritize gas supplies to villages in different climates (separate from the provinces), a more basic and logical framework based on economic calculations and considering the opportunity cost and actual prices was used. Extraction of indices such as domestic and actual price of consumption basket of petroleum products for households by segregating the villages of the provinces, the ratio of the intensity of rural to urban gas consumption, and the rate of intensity change of the consumption of natural gas into the products after the replacement, strengthened the methodology framework and also enhanced the accuracy of outputs. Finally, from a national perspective, villages in each province, based on households and distances from natural gas sources, were prioritized and a specific and applicable framework was provided in each province.

The results of gas supply prioritization to the villages of the country based on the established framework

Number of target village households												states
160	140	120	100	90	80	70	60	50	40	30	20	
10	7	6	5	4	3	3	3	2	2	1	1	East Azarbaijan
11	9	8	7	6	5	4	3	2	2	1	OP	west Azarbaijan
8	7	6	5	4	3	3	2	2	1	OP	OP	Ardebil
3	2	2	1.5	1	OP	OP	OP	OP	OP	OP	OP	Esfahan
12	10	8	6	6	6	4	3	2	2	1	OP	Ilam
EL	EL	EL	EL	EL	EL	EL	EL	EL	EL	EL	EL	Bushehr
10	8	7	6	5	4	3	2	2	1	1	OP	Tehran
40	34	27	21	19	16	13	11	8	6	4	2	Chahar Mahal Bakhtiari
6	5	4	3	3	2	1	OP	OP	OP	OP	OP	South Khorasan
...	...	...	...	...	...	...	...	...	...	...	...	...

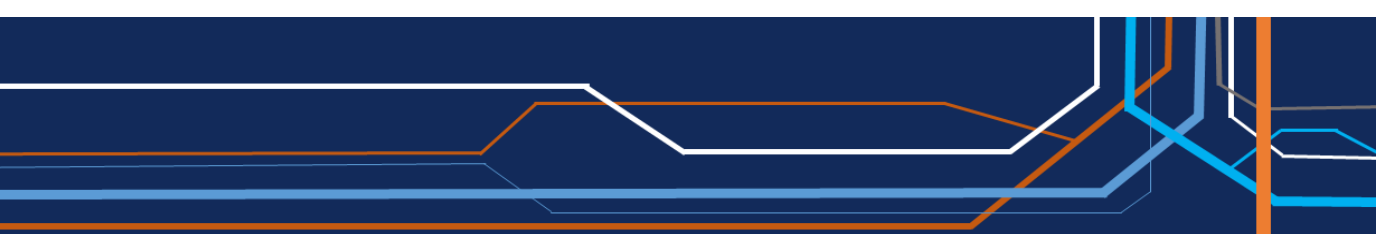

## Fundamental studies of Oxy-fuel Boilers-Phase I, funded by Metso, Sweden & Finland

Client: Metso Power Oy, Finland

Date: 2009-2011

Director project: Dr. Sadegh Seddighi

Project associate members: Dr. Sadegh Seddighi

Project type: Engineering, Laboratory/Pilot Plant Implementation

Project collaborator: Fortum Company (Sweden), Chalmers University

### Summary of project:

This project which was funded by Scandinavian energy companies of Metso Power and Fortum, aimed at developing and encoding tools for the design and scale-up of oxy-fuel boilers across a wide range of operational conditions. The work

comprises fluid dynamics, combustion, and heat transfer and uses expressions that are proposed in this project or derived from the literature, together with experimental data obtained under both oxy-fuel-fired and air-fired conditions.

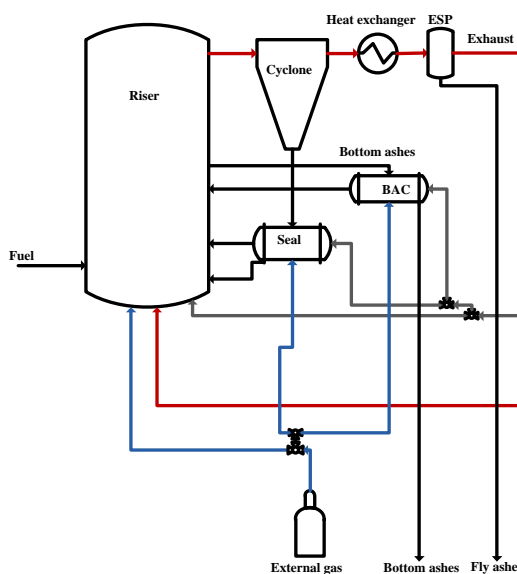
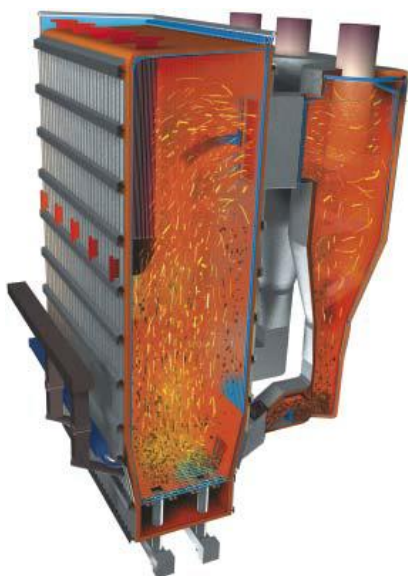

## Design of large-scale Oxy-fuel Boilers-Phase II, funded by Valmet, Finland

Client: Valmet, Finland

Date: 2011-2014

Director project: Dr. Sadegh Seddighi

Project associate members: Dr. Sadegh Seddighi

Project type: Engineering, Laboratory/Pilot Plant Implementation

Project collaborator: Fortum Company (Sweden), Chalmers University

### Summary of project:

This project carried out model simulations and validations for a broad range of operational conditions, involving both oxy-fuel firing and air-firing. The results were in good agreement with the data obtained in

this project using laboratory-scale (100-kW) and 4-MW industrial-scale, oxy-fuel-fired units. The designed model is used subsequently to design of a utility-scale (300–1100 MW) oxy-fuel-fired CFB boiler for the client.

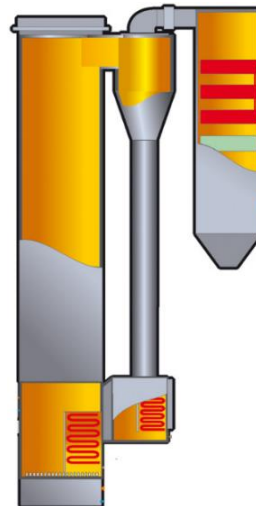
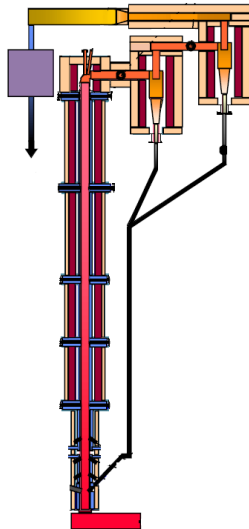



## Developing an Appropriate Model and Practical Application of the Model for Estimating Natural Gas Demand in Khuzestan Province in a 20 Year-Old Horizon

Date: 2009

Director project: Professor Majid Amidpour

Project type: Feasibility/Simulation study

Project collaborator: K.N. Toosi University of Technology (KNTU)

### Summary of project:

In this research project, the detailed and regional demand for natural gas in Khuzestan province, according to each city, was simulated and estimated using energy system programming language, Leap. All sectors of the natural gas industry including domestic, commercial, industry, agriculture, transportation, petrochemicals, pumping stations and energy transmission stations, injection into oil reservoirs and oil and gas extraction, oil and gas refineries and electricity generation were accurately modelled and analyzed. Results including the annual demand process for natural gas, hour peak of gas demand and the number of potential customers in the 20-year horizons were calculated and extracted in the consumable parts of each city (cities in separated from and villages in a cumulative manner). The results of the project indicate that the total annual demand for natural gas in Khuzestan province will reach 56.6

billion cubic meters per year with considering the injection and 46.4 billion cubic meters without taking into account the injection in the perspective of 2025, due to the establishment of diverse, large and energy-intensive industries in the province. The daily peak of natural gas demand, with an injection of 226 million cubic meters per day, will amount to 198 million cubic meters per day, without injection. The province's gas demand forecast software was also prepared and presented with results. This software is flexible, which by training it to the respected experts, the company was able to make unpredictable changes and update it in the coming years. Examining the validity of the results of the project indicates its convergence with the total demand for natural gas in the country, and also in coordination with the opinions of the respected experts of the province gas.

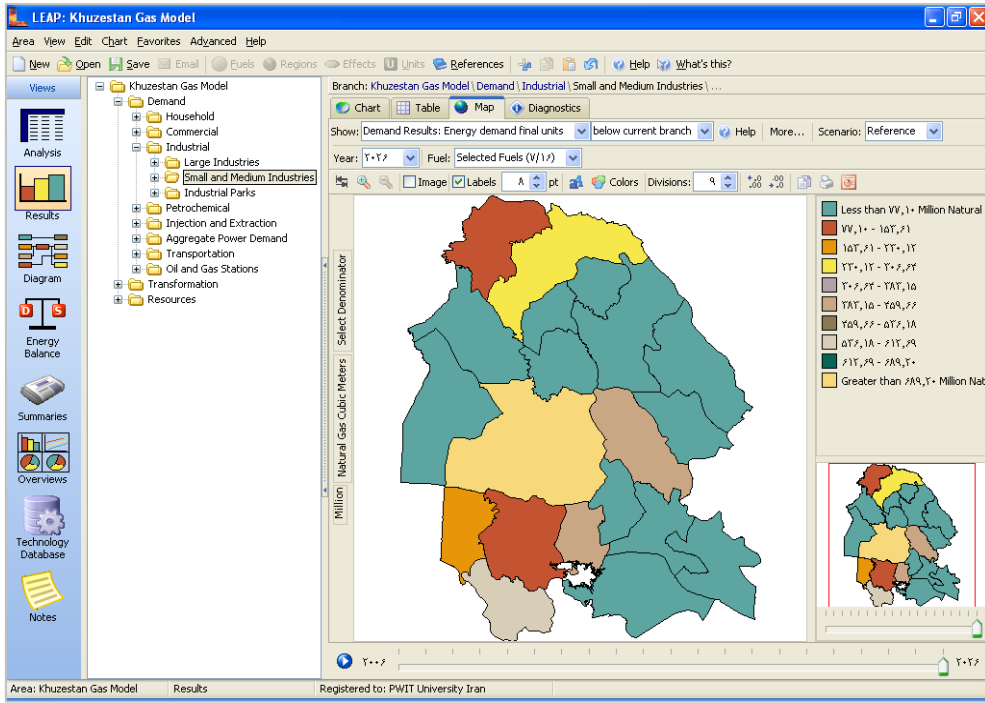

## Commissioning of two automated phased-array ultrasonic testing systems

**Plant Location:** National Iranian Gas Company – District 3

**Client:** National Iranian Gas Company – Iranian Gas Transmission Co.

**Date:** 2013-2015

**Director project:** Prof. Farhang Honarvar

**Project type:** Commissioning

**Project collaborator:** K. N. Toosi University of Technology (KNTU)

### Summary of project:

Iranian Gas Transmission Company (IGTC) purchased two units of automated phased-array ultrasonic testing systems, PipeWIZARD Ver. 2, from RD Tech (Canadian Company) in 2002. The PipeWIZARD is an automated girth weld inspection system which is suitable for in-site weld inspection in extreme environments. It uses conventional UT and phased array techniques. Due to the international sanctions against Iran, IGTC was not

able to get after-sales services (e.g., installation and commissioning) for these two units. Therefore, IGTC decided to invite domestic NDT experts from the KNTU to provide support for the initial set-up and installation of the PipeWIZARD systems at IGTC's premises. Commissioning stage of the units was successfully completed by measuring and interpreting the results obtained from a number of NDT reference standards.



## Design and development of a long-range ultrasonic testing (LRUT) system as well as the optimization of hydrostatic testing for the inspection of gas transmission pipelines

**Plant Location:** Bushehr - Iran

**Client:** National Iranian Gas Company-Bushehr Province Gas Company

**Date:** 2014

**Completed Date:** Ongoing

**Director project:** Prof. Farhang Honarvar

**Project faculty members:** Dr. Soheil Nakhodchi

**Project type:** Laboratory/Pilot Plant Implementation

**Project collaborator:** K. N. Toosi University of Technology (KNTU) and Parsian Advanced Ultrasonic Testing ([www.paut.ir](http://www.paut.ir))

### Summary of project:

Recent studies show that the Hydrotesting as the most common method employed for the pipeline integrity may cause damages to the structure, however, it might also improve some mechanical properties of the pipelines. Due to the growing use of hydrotesting of the pipelines in oil and gas industries, the first part of the project was therefore devoted to studying standards and procedures of this technique in order to provide all technical requirements and

optimized instructions. Furthermore, at the second part of the project, a new emerging technique so-called Long Range Ultrasonic Testing (LRUT) was designed, developed and implemented in order to replace the traditional Hydrostatic testing. This reliable and cost-effective technique takes advantage of guided waves to inspect and screen pipelines for damages at the long distances in a pulse-echo configuration mode.

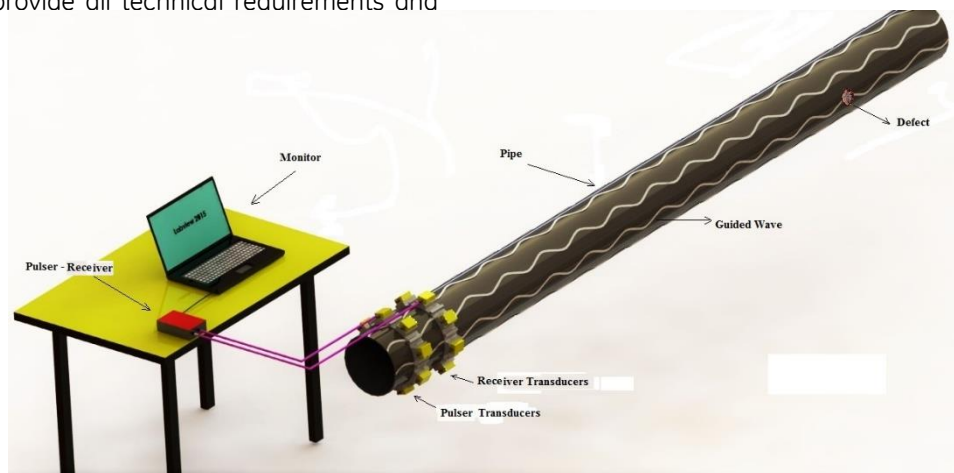

## A Hydro-Thermo-Mechanical Model for Black Oil Reservoirs

Client: K. N. Toosi University of Technology

Date: 2008-2013

Director project: Dr Hasan Ghasemzadeh

Project type: Engineering, Modeling

Project collaborator: Dr. Sadrnejad, Dr. Ghoreishian

### Summary of project:

A fully coupled thermo-hydro-mechanical model for simulating the black-oil type flow in stress sensitive reservoirs was presented. Thermal oil recovery processes involve high pressures and temperatures, leading to large volume changes and induced stresses. To identify these deformation and stresses, we developed a thermal reservoir simulator. The accuracy and efficiency

of the model was verified by simulating some experiments and benchmark problems. The key objectives of the project include:

- Development of theoretical knowledge of integrated equations of heat and black-oil flow in deformable reservoir.
- Software development for numerical solution of multiphase flow in deformable porous media.

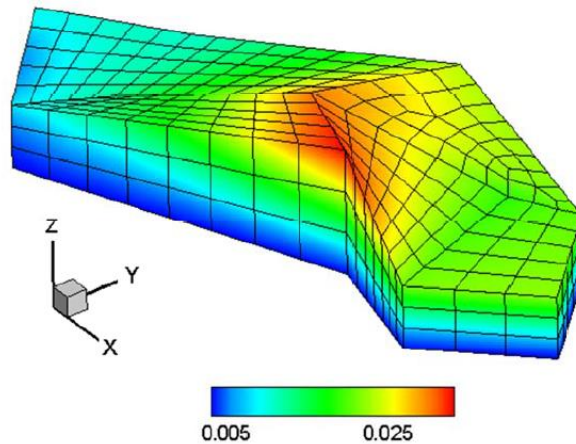

## Multiscale Modeling of Oil Transport in Deformable Porous Media

**Client:** K. N. Toosi University of Technology

**Date:** 2009-2015

**Director project:** Dr Hasan Ghasemzadeh

**Project type:** Engineering, Modeling

**Project collaborator:** Dr. Sadrnejad, Dr. Taheri

### Summary of project:

Reservoir formations typically display high degrees of spatial variations over multiple length scales. Moreover, several physical phenomena affect the flow pattern in different hierarchies. However, a full description of flow and deformation that includes all these scales exceeds the current computational capabilities. To overcome this deficiency, each physical effect should be treated separately on its area of influence. In this project the finite element method is combined with Multiscale Finite Volume (MSFV) to solve the solid equilibrium and fluid flow equations. The accuracy and efficiency

of the code was verified by simulating some experiments and benchmark problems which the results show the high computation efficiency of developed code. The key objectives of the project include:

- Development of theoretical knowledge of governing equations of multiphase flow in deformable reservoir.
- Software development for numerical solution of the Multiscale/Multiphysics Mixed Geomechanical Model.

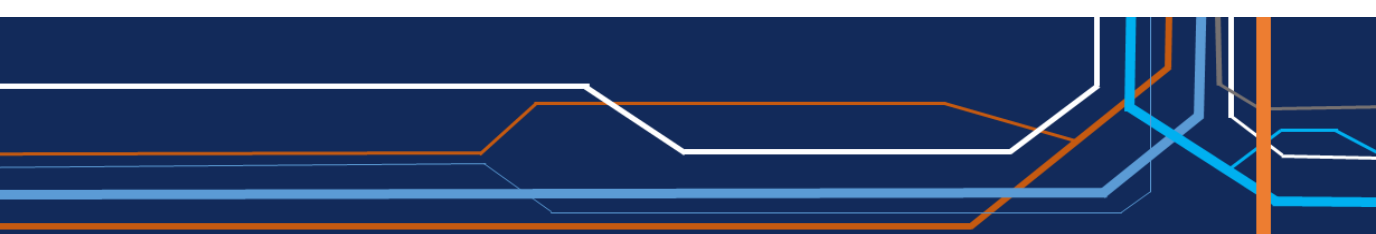
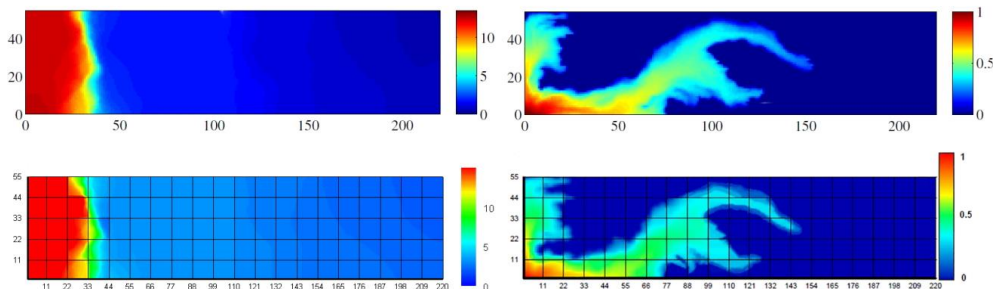

## Oil Flow Modeling In Naturally Fractured Reservoirs by a Fully Coupled Thermo-Hydro-Mechanical Approach

Client: K. N. Toosi University of Technology

Date: 2015

Director project: Dr Hasan Ghasemzadeh

Project type: Engineering, Modeling

Project collaborator: Mrs Harif Bilandi

### Summary of project:

More than 60 percent of oil reservoirs worldwide, quite all of the thermal energy reservoirs and most of the Iranian oil reservoirs are placed in fractured formations. These fractures are of great influence in the medium properties and extraction behavior. The project focuses on code developing in Geomechanics

and multi-phase flow in naturally fractured reservoirs by a fully coupled thermo-hydro-mechanical approach. This program solves the equations governing in a dual-porosity medium consisting of matrix and fractures with multiphase flow in a geometrically complex medium in a fully coupled approach.

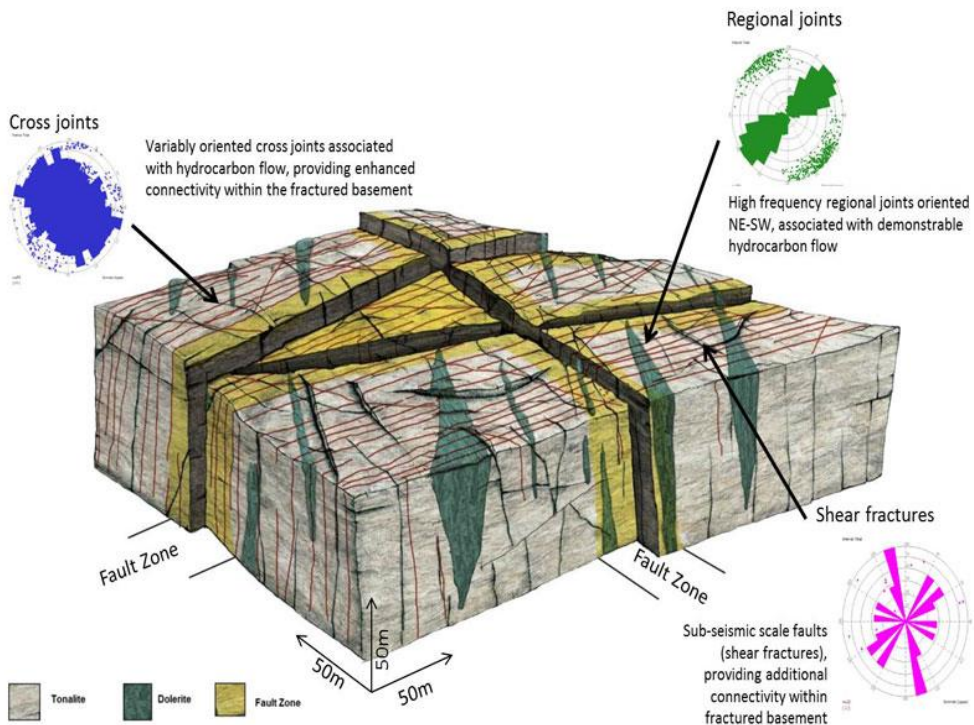



## Pirani vacuum gauge with platinum filament

**Client:** Hezareh-Sevom Company (<http://www.hezare-sevom.ir/fa/>)

**Date:** 2014-2017

**Director project:** Prof. Faramarz Hossein-Babaei

**Project type:** Industrial implementation

**Project collaborator:** Ehsan Yousefiazari, Armin Alizadeh

### Summary of project:

**P**irani sensor is the most commonly utilized vacuum gauge. This device measures low atmospheric pressure by estimating thermal conductivity of the prevailing atmosphere. The nominal measurement range is 0.1-1000 Pa, which partly covers the vacuum range produced by rotary pumps. These gauges present fairly reproducible measurement results in clean atmosphere chambers, but

presence of atmospheric contaminations can irreversibly hinder their accuracy. The sensor head in Pirani gauge comprises a metallic filament, the electrical resistance variations of which is monitored with an appropriately designed bridge. Commonly, tungsten wires are utilized for this purpose; we have altered the design to allow using platinum filaments instead. The device is at the stage of industrial production.



The fabricated Pirani vacuum gauge

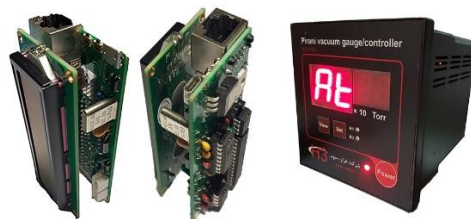

Pirani hardware developed in this project.



## A gold/organic semiconductor diode for ppm-level humidity sensing

Client: K. N. Toosi University of Technology  
 Date: 2011-2015  
 Director project: Prof. Faramarz Hossein-Babaei  
 Project type: Laboratory implementation  
 Project collaborator: Dr. Pejman Shabani

### Summary of project:

Measuring humidity in ppm level is of major technological importance, particularly in petrochemical plants where the activity of nanoporous catalysts determines the process progress rates, and also in low-loss optical fiber production units where hygrometry at extremely low humidity levels in air, vacuum, and inert gas backgrounds is a vital necessity. In this project, a novel electronic humidity sensor is fabricated by depositing gold nanolayers on an air-stable hydrophobic organic semiconductor, oxidized poly[2-methoxy-5-(2-

ethylhexyloxy)-p-phenylene vinylene] (MEH-PPV). The device demonstrates high sensitivity at H<sub>2</sub>O concentrations as low as ~1 ppm in air, vacuum and inert backgrounds. The presence of gases such as CO<sub>2</sub> and H<sub>2</sub> in substantial concentrations and oxygen partial pressure variations in air do not interfere with the sensing process. The device is affordable and easy to fabricate in a wide range of sizes and shapes and is anticipated to find a variety of applications in different branches of science and technology.

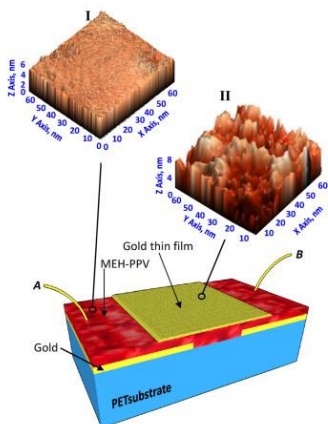

Structure of the fabricated humidity sensor.

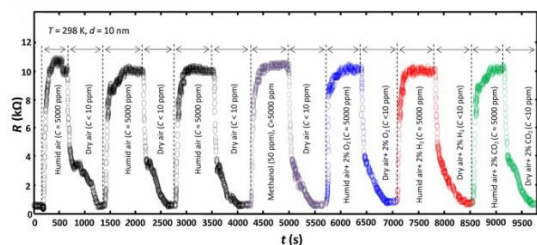

Humidity sensing at different background atmospheres.

## PEDOT:PSS-coated microchannels: a selective filter for volatile organic compounds

Client: K. N. Toosi University of Technology

Date: 2015-2018

Director project: Prof. Faramarz Hossein-Babaei

Project type: Laboratory implementation

Project collaborator: Dr. Ali Hooshyar Zare

### Summary of project:

In this project, a sharply selective filter for volatile organic compounds is designed and fabricated. The device is a microchannel with Poly(3, 4-ethylenedioxythiophene)-poly(styrenesulfonate) (PEDOT:PSS)-coated walls which can be used to separate ppm-level contaminations from background gases in a microfluidic circuit. This behavior stems from the physicochemical properties of the surface of the functional coating applied to the channel walls, which are amplified by the physics of the microfluidic channel; the filtering action disappears in large cross-section channels. The coated channel

transports hydrogen, carbon monoxide, hexane and benzene similar to the uncoated while effectively blocking both diffusion and drift of methanol and ethanol. Separation factor between n-hexane and ethanol is larger than 103. These microchannels coupled to appropriate sensors can be considered for numerous applications in selective chemical sensing and biomarker detection. At its present configuration, the introduced device can be utilized for detecting low levels of carbon monoxide or benzene in highly alcohol-contaminated background atmosphere.

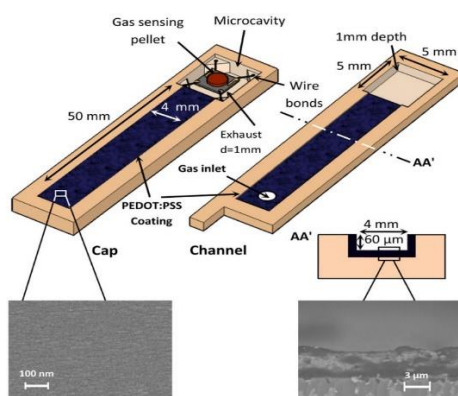

The fabricated PEDOT:PSS-coated microfluidic channel integrated with a gas sensor.

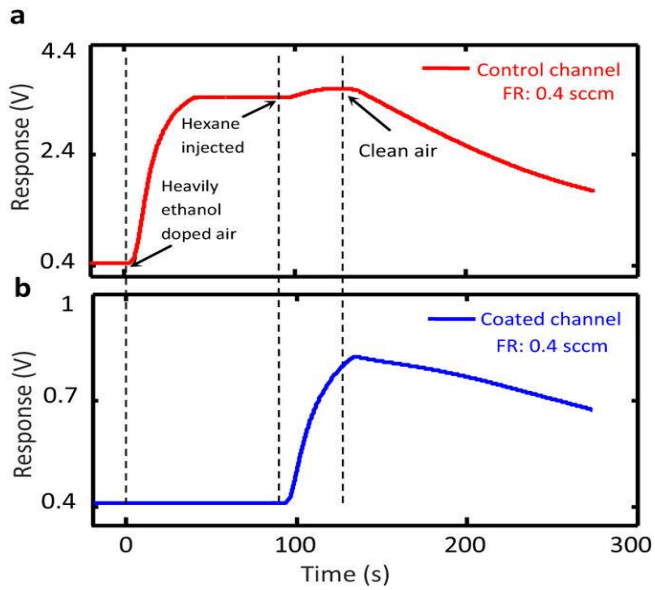

The selective flow of contaminants through the uncoated (a) and PEDOT:PSS-coated microchannels.

## Tin oxide gas sensor on tin oxide microheater for methane sensing

**Client:** K. N. Toosi University of Technology

**Date:** 2015- Ongoing

**Director project:** Prof. Faramarz Hossein-Babaei

**Project type:** Pilot plant implementation

**Project collaborator:** Mohsen Gharesi, Maryam Moalaghi

### Summary of project:

The explosive nature of methane and its role in global warming have made detecting its leakage important. Significant amounts of natural gas are lost along pipelines causing billion-dollar economic losses each year. The common chemiresistive methane sensors fail to satisfy the quality requirements for long-term operation in harsh environs. Particularly, the RuO<sub>2</sub> microheaters utilized in these sensors deteriorate in reducing atmospheres and cannot provide the high temperatures required for

methane detection in long term. In this project, a tin oxide gas sensor is fabricated on a tin oxide microheater which can stably operate at temperatures as high as 850 °C. Both components are produced by ultrasonic spray pyrolysis of tin chloride solutions on alternative sides of an alumina chip. Thermally stable electrical contacts are formed by diffusion bonding of gold wire segments. The device can detect 50 ppm of methane in normal atmosphere with a response time of 10 s.



Photograph and SEM micrographs of a tin oxide methane sensor.

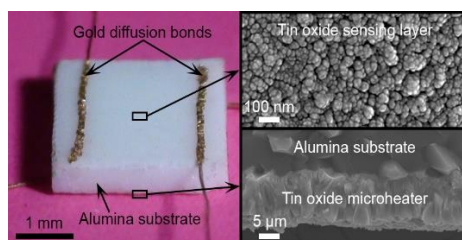

Photograph and SEM micrographs of a tin oxide methane sensor.



## Single sensor electronic nose, trainable for different industrial applications

Client: K. N. Toosi University of Technology

Start Date: 2005-2017

Director project: Prof. Faramarz Hossein-Babaei

Project type: Laboratory implementation

Project collaborator: Dr. Seyed Mohsen Hosseini-Golgoo, Dr. Amir Amini

### Summary of project:

Sensor array-based electronic noses suffer from multi-dimensional drift and require cumbersome calibrations frequently. In this project, a virtual array-based electronic nose is developed which can repeatedly operate over long term. The device utilizes only one chemiresistive gas sensor which is stimulated with thermal shocks of varying profiles and

magnitudes. The temporal responses of the sensor, recorded as voltage variations, are processed for obtaining information regarding the nature of the gaseous analyte. The system is used for the comparison and recognition of analyte classes after appropriate training. The device can discriminate among both simple and complex odors in only 4 s.

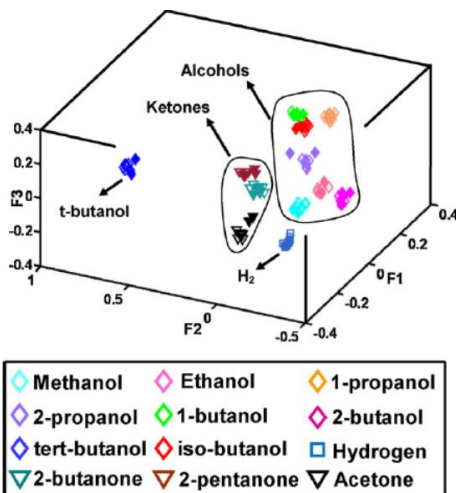

3-dimensional feature space showing successful discrimination among 12 simple odors.

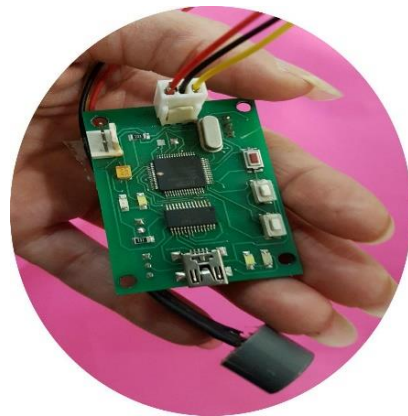

Photograph of the developed single-sensor electronic nose.

### Microfluidic electronic tongue

**Client:** K. N. Toosi University of Technology

**Date:** 2009- Ongoing

**Director project:** Prof. Faramarz Hossein-Babaei

**Project type:** Laboratory implementation

**Project collaborator:** Dr. Kianoosh Nemati, Asma Sourì, Hasti Sardari

### Summary of project:

An electronic tongue is developed in which the discriminative information are obtained by monitoring the diffusion progress rates of ionic species in liquid-filled microfluidic channels. The fabricated prototype is made of two microfluidic channels and can classify simple and complex analytes and distinguish among sour and salty electrolytes.

Owing to its simplicity and inexpensiveness, the device can be disposably utilized for fast recognition of liquid analytes. Electronic tongues are sought after for monitoring the contents and comparison of the liquids with complex ingredients in various branches of food, chemical, and petrochemical industries. Water quality monitoring is an example.

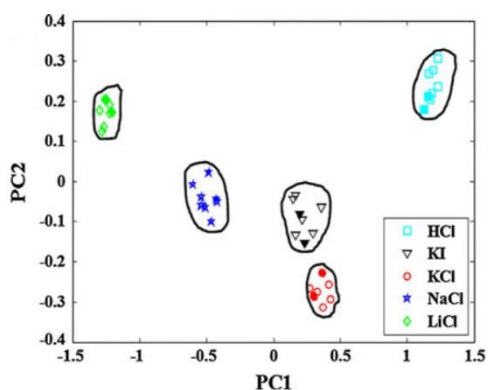

Feature space classification of analytes using the developed electronic tongue.

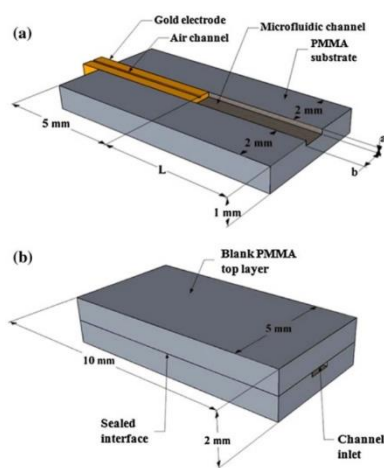

The fabricated microfluidic channel before (a) and after (b) placing the cap.

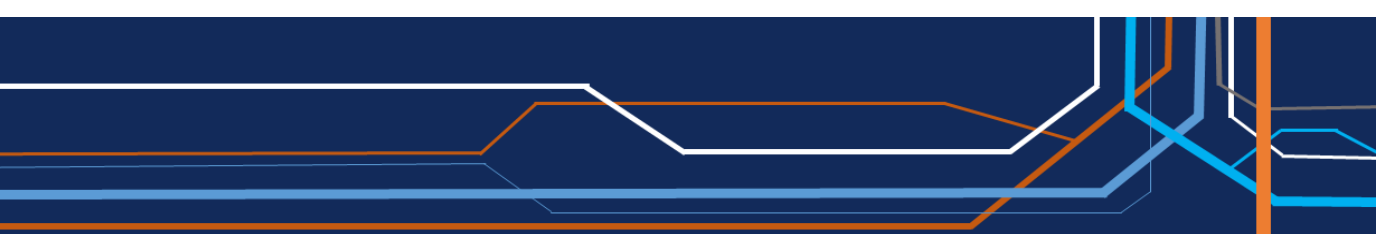



## SnO<sub>2</sub>:F conducting films for long-life transparent electronics

Client: Hezareh-Sevom Company (<http://www.hezare-sevom.ir/fa/>)

Date: 2016- Ongoing

Director project: Prof. Faramarz Hossein-Babaei

Project type: Pilot plant implementation

Project collaborator: Mohsen Gharesi, Alireza Ranjkesh

### Summary of project:

Transparent conductors (TCs) are in great demand in electronic industries; local production of TCs even at laboratory scale is still lacking. In this project, fluorine doped tin oxide (FTO) films are fabricated and characterized as TCs. The films are grown on soda lime and silica glass substrates by ultrasonic spray pyrolysis. The products exhibit sheet resistances in the order of  $10 \Omega \cdot \text{sq}^{-1}$  and fine transparency in the visible spectrum. Thermal annealing of FTO films in air at temperatures as high as  $500^\circ\text{C}$  does not alter their electrical and optical

characteristics. Electrical contacts of ohmic quality are made by both silver paste printing and diffusion bonding. Owing to their high temperature stability and resistance to harsh environs, the fabricated devices can function as long-life transparent electrodes and defrosters in many electronic, optoelectronic, and electrochemical devices. The device is used for the manufacturing of windows with active defogging implement for storage units operating below room temperature at chemical and petrochemical industries.

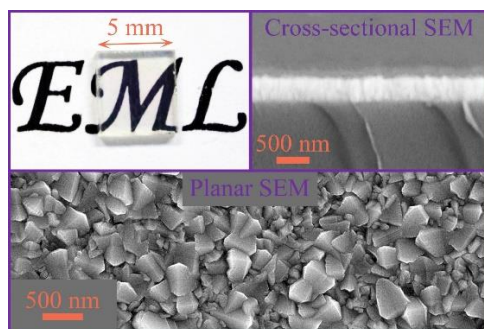

Photograph and SEM micrographs of FTO TCs deposited on soda-lime glass slides.



An FTO coated fused silica glass.

## Ten micron-thick undoped SnO<sub>2</sub> layers grown by spray pyrolysis for microheater fabrication

**Client:** Exciton Company (<http://excitonco.ir/fa/>)

**Date:** 2013-2017

**Director project:** Prof. Faramarz Hossein-Babaei

**Project type:** Pilot plant implementation

**Project collaborator:** Mohsen Gharezi, Mohammad Ansari

### Summary of project:

**M**icron-thick layers of tin oxide are advantageous for the fabrication of high power density transparent microheaters operating at elevated temperatures and harsh environs. In this project, 10 μm-thick SnO<sub>2</sub> layers are grown on alumina substrates through ultrasonic spray pyrolysis deposition. Produced layers function as long life heating elements operating at temperatures as high as 1000 °C. The required ohmic contacts are formed through diffusion bonding of gold wires to the SnO<sub>2</sub> deposits. Long term stability of the fabricated microheaters is examined in a month of continuous operation at 600 °C; the

devices show only ~5% surface temperature change, demonstrating exceptional high temperature stability of the tin oxide microheaters. The thermal stability of the composition and microstructure, the negative temperature coefficient of resistance, and the proper range of sheet resistance, render the grown layers suitable for long life microheater fabrication. The device is utilized as low voltage fuel igniter in exhaust systems for combustion safety units in chemical and petrochemical reactors. It is also used for providing the elevated temperatures required for the operation of the resistive methane sensors.

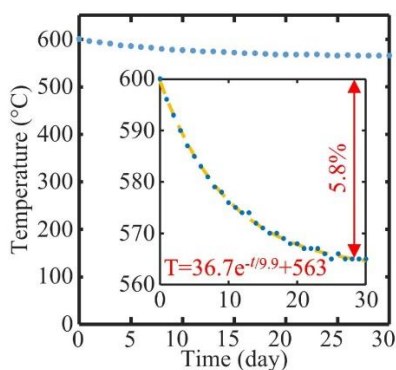

Long-term performance of a tin oxide microheater.

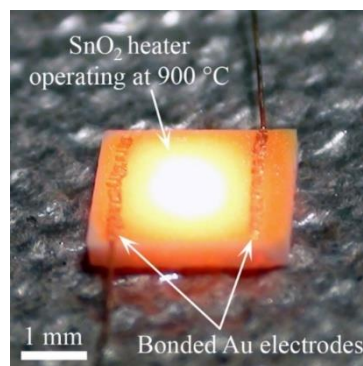

Photograph of a tin oxide microheater.



## PART III: Faculty Members



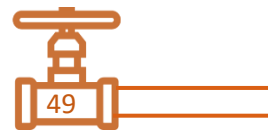

**Dr. Mahdi Aliyari Shooredeli**

Assistant Professor

Control & Systems Department

Faculty of Electrical Engineering

**Email:** [aliyari@kntu.ac.ir](mailto:aliyari@kntu.ac.ir)

**Phone No:** +98 21 84062403

**Fax:** +98 21 84062168

**Personal website:** [https:// wp.kntu.ac.ir/aliyari/](https://wp.kntu.ac.ir/aliyari/)

**Education:**

**B.Sc.:** Electrical Engineering, K. N. Toosi University of Technology, Tehran.

**M.Sc.:** Control System Design, K. N. Toosi University of Technology, Tehran.

**Ph.D.:** Control System Design, K. N. Toosi University of Technology, Tehran.

**Research interests:**

- Fault Diagnosis
- System Identification
- Soft Computing
- Fuzzy and Neural Networks

**Office Address:**

Faculty of Electrical Eng., K.N. Toosi University of Technology (KNTU), Sayyed Khandan, P.O. Box: 16315 1355, Tehran, Iran.



**Dr. Yazdan Amerian**

Assistant Professor

Faculty of Geodesy and Geomatics Engineering

K.N.Toosi University of Technology

**Email:** amerian@kntu.ac.ir

**Phone No:** +98 21 88877071 (Ext: 203)

**Fax:** + 98 21 88786213

**Personal website:** <https://wp.kntu.ac.ir/amerian/>

**Education:**

**B.Sc.:** Geomatics Engineering, University of Tehran, Tehran, Iran, 1996-2000.

**M.Sc.:** Geodesy, K.N. Toosi University of Technology, Tehran, Iran, 2000-2002.

**Ph.D.:** Geodesy, K.N. Toosi University of Technology, Tehran, Iran, 2008-2013.

**Research interests:**

- Geodesy
- Satellite Geodesy
- Global Navigation Satellite Systems
- GNSS Remote Sensing
- Approximation Methods in Geodesy

**Academic/Industrial Career:**

- Head of GIS and RS Center (The Last Position), Exploration Directorate, National Iranian Oil Company (Apr 2003 – Sep 2013)
- Head of Department of Geodesy, Faculty of Geodesy and Geomatics Engineering, K.N. Toosi University of Technology (Oct 2013 – Jan 2017).
- Director of Physical Geodesy and Gravimetry Laboratory, Faculty of Geodesy and Geomatics Engineering, K.N. Toosi University of Technology (Jan 2014 – Present)
- Vice Dean for Research and Technology, Faculty of Geodesy and Geomatics Engineering, K.N. Toosi University of Technology (Nov 2016 – Present).

**Office Address:**

Faculty of Geodesy and Geomatics Engineering, K.N.Toosi University of Technology, No. 1346, Vali-Asr Ave, Mirdamad Cross, P.O.Box: 15875-4416, Tehran, Iran.



**Dr. Majid Amidpour**

Professor

Energy systems

Faculty of Mechanical Engineering

**Email:** amidpour@kntu.ac.ir

**Phone No:** +98 21 8406 3222

**Fax:** +98 21 88779476

**Personal website:** <https://wp.kntu.ac.ir/amidpour/>

**Education:**

**B.Sc.:** Chemical Engineering, Tehran University, Tehran, Iran, 1984-1988.

**M.Sc.:** Process Integration & Energy Conservation, UMIST, Manchester, UK, 1992-1994.

**Ph.D.:** Process Integration & Energy Conservation, UMIST, Manchester, UK, 1994-1997.

**Research interests:**

- Energy saving in industry
- Process improvement
- Pinch technology
- Process retrofit
- Water targeting
- Energy efficiency
- Exergy analysis
- Utility selection
- Debottlenecking
- Conceptual design
- Low temperature process
- Pilot plant research
- Energy Modelling

**Academic/Industrial Career:**

- Head of energy & process optimization Department in IR. R&D
- Research deputy in Iranian research and developing center for chemical industry
- Head of IR.R&D for chemical industry
- Research consultant in ministry of industry (Innovation and energy saving)
- Head of Energy system Engineering
- Consultant Oil and Energy Ministries Company's in Iran
- Managing Board of Iran Energy Association
- Board of research in oil distribution Iranian company
- Three dimensional Gas Refinery Model for phase 2-3 South Pars gas reserve
- Energy saving in Oil & Gas Industry (Gas refinery and petrochemical Industry)

**Office Address:**

Faculty of Mechanical Eng. of K. N. Toosi University of Technology Vanak Square, Molla-Sadra, Pardis  
Box 19395-1999Tehran, Iran.



### Dr. Saeed Asil Gharebaghi

Assistant Professor

Civil Engineering Department

Email: [asil@kntu.ac.ir](mailto:asil@kntu.ac.ir)

Phone No: +98 21 88 77 94 73

Fax: +98 21 88 77 94 76

Personal website: <https://wp.kntu.ac.ir/asil/>

#### Education:

**B.Sc.:** Civil Engineering Department, Sharif University of Technology, Tehran, Iran. 1991 – 1996.

**M.Sc.:** Civil Engineering Department, Sharif University of Technology, Tehran, Iran. 1996 – 1998.

**Ph.D.:** Civil Engineering Department, Sharif University of Technology, Tehran, Iran. 2001-2006.

#### Research interests:

- Parallel Processing
- Numerical Methods
- Three-Dimensional Adaptive Finite Element
- Optimization Methods
- Chaos Theory
- Structural Control
- Software Development for Engineering/Industrial Applications
- Mesh Generation

#### Academic/Industrial Career:

- Technical Deputy in Tosee Siloha Co. (2006-2011)
- Head of Structural Engineering Department (2012-2013)
- Industrial Relations Manager of the Civil Engineering Faculty (2010-2012)
- University Administrative Affairs Management (2013)
- Design and Implementation of HAMR3D (H-Adaptive mesh refinement program for three-dimensional models). (2004-2006)
- Co-operation in SUT-DAM project, Sharif University of Technology, Tehran, Iran. (2004-2006)

#### Office Address:

Civil Engineering Faculty K.N. Toosi University of Technology No. 1346, Vali Asr Ave., Mirdamad Cross, P.O. Box: 15875-4416, Tehran, Iran.



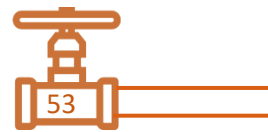

**Dr. Omid Reza Barani**

Assistant Professor  
Civil Engineering Department

**Email:** barani@kntu.ac.ir

**Phone No:** +98 21 88779474-5

**Fax:** +98 21 88779476

**Personal website:** <https://wp.kntu.ac.ir/barani/>

**Education:**

**B.Sc.:** Sharif University of Technology, 1999.

**M.Sc.:** Isfahan University of Technology, 2002.

**Ph.D.:** Sharif University of Technology, 2010.

**Research interests:**

- Computational Geomechanics
- Modeling Fractures in Porous Media
- Fracture Mechanics
- Mechanics of Quasibrittle Materials

**Office Address:**

Civil Engineering Faculty K.N. Toosi University of Technology No. 1346, Vali Asr Ave., Mirdamad Cross, P.O. Box: 15875-4416 Tehran, Iran.

**Dr. Hamid Ebadi**

Professor

Department of Photogrammetry and Remote Sensing

Geodesy &amp; Geomatics Faculty

**Email:** ebadi@kntu.ac.ir**Phone No:** +98 21 88770218**Fax:** +98 21 88786213**Personal website:** <https://wp.kntu.ac.ir/ebadi/>**Education:****B.Sc.:** in Surveying Engineering, K.N. Toosi University of Technology, Tehran, Iran 1984-1988.**M.Sc.:** in Geomatics Engineering, Department of Geodesy and Geomatics Eng, University of New Brunswick, Fredericton, Canada 1991-1993.**Ph.D.:** in Geomatics Engineering, Department of Geomatics Engineering, University of Calgary, Calgary, Canada 1993-1997.**Research interests:**

- GPS (Global Positioning System)
- GIS (Geographic Information System)
- Design and Implementation of Applied GISs

**Academic/Industrial Career:**

- Head of the Department of Geomatics Eng, K.N.Toosi University of Technology, Tehran, Iran, (Jan 2001-March 2003)
- Vice-Dean, Research Affairs, Faculty of Geomatics Eng, K.N.Toosi University of Technology, Tehran, Iran, (March 2003-Oct 2004)
- Vice-Dean, Educational Affairs, Faculty of Geomatics Eng, K.N.Toosi University of Technology, Tehran, Iran, (Oct 2004-March 2005)
- Vice-Dean, Research Affairs, Faculty of Geomatics Eng, K.N.Toosi University of Technology, Tehran, Iran, (March 2005-June 2006)
- Vice-Dean, Educational Affairs, Faculty of Geomatics Eng, K.N.Toosi University of Technology, Tehran, Iran, (June 2007- 2010)
- Dean, Faculty of Geomatics Eng, K.N.Toosi University of Technology, Tehran, Iran, (Nov 2013- now)

**Office Address:**

Faculty of Geodesy &amp; Geomatics Engineering, K. N. Toosi University of Technology, No. 1346, Vali-Asr Ave, Mirdamad Cross, P.O.Box: 15875-4416 Tehran, Iran.

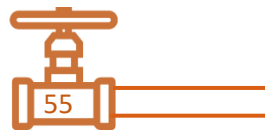

**Dr. Alireza Fatehi**

Associate Professor  
Control & Systems Department  
Faculty of Electrical Engineering

**Email:** fatehi@kntu.ac.ir

**Phone No:** +98 21 84062207

**Fax:** +98 21 88462066

**Personal website:** <https://wp.kntu.ac.ir/fatehi/>

**Education:**

**B.Sc.:** Electrical Engineering-Electronics, Isfahan University of Technology, Isfahan, Iran, 1985-1990.

**M.Sc.:** Electrical Engineering-Control Systems, Tehran University, Tehran, Iran, 1992-1995.

**Ph.D.:** Electrical Engineering-Control Systems, Tohoku University, Sendai, Japan, 1998-2001.

**Research interests:**

- Process Control
- Fault Detection
- Soft Sensor
- Model Predictive Controller
- Intelligent Control Systems
- Multiple Modeling and Control
- System Identification
- Industrial Automation

**Academic/Industrial Career:**

- Causality study on oil recovery in oil-sand extraction unit
- Optimization of water/steam distribution in SAGD process of oil-sands industry
- Commissioning and consulting f several cement plants.
- Design and Construction of PH neutralization and Quadruple- Tank Pilot Plants.
- Advanced process control (APC) system for process plants.
- Application of condition monitoring in oil refinery and processing plants.

**Office Address:**

Faculty of Electrical Eng., K.N. Toosi University of Technology (KNTU), Sayyed Khandan, P.O. Box: 16315-1355, Tehran, Iran.

**Dr. Hasan Ghasemzadeh**

Associate Professor

Civil Engineering Department

**Email:** Ghasemzadeh@kntu.ac.ir**Phone No:** +98 21 8877 9623**Fax:** +98 21 8877 9476**Personal website:** <https://wp.kntu.ac.ir/ghasemzadeh/>**Education:**

**B.Sc.:** Civil Engineering, Civil engineering Department, Iran University of Science & Technology, Tehran, Iran.

**M.Sc.:** Geotechnical Engineering, K.N. Toosi University of Technology, Tehran, Iran.

**Ph.D.:** Geotechnics, Centre d'Enseignement et de Recherche en Mécanique des Sols, Ecole Nationale des ponts et chaussées, (ENPC – CERMES), Paris, France.

**Research interests:**

- Oil and gas reservoir modeling
- Multiphase multi-component transport in geomaterials
- Wave transmission in elasto-plastic media
- Theoretical and numerical modeling of soil and rock

**Academic/Industrial Career:**

- A good experience and knowledge in international activities and multidisciplinary industrial project Oil and gas reservoir modeling project and research
- Copper and steel making projects management
- Management and supervision of geomechanical project

**Office Address:**

Civil Engineering Faculty, K.N. Toosi University of Technology, No. 1346, Vali Asr Ave., Mirdamad Cross, P.O. Box: 1996715433, Tehran, Iran.



**Dr. Mohammad Mohsen Hatami**

Associate Professor

Physics department

**Email:** m\_hatami@kntu.ac.ir

**Phone No:** +98 21 23064398

**Fax:** +98 21 23064218

**Personal website:** <http://wp.kntu.ac.ir/hatami>

**Education:**

**B.Sc.:** Physics, Teacher Training University, Tehran, Iran, 1996-2000.

**M.Sc.:** Physics, Shahid Beheshti University, Tehran, Iran, 2000-2004.

**Ph.D.:** Photonics, Shahid Beheshti University, Tehran, Iran, 2005-2010.

**Research interests:**

- Plasma surface modification
- Plasma instability

**Academic/Industrial Career:**

- Research and teaching position

**Office Address:**

Physics department, Faculty of Physics, K.N. Toosi University of Technology, Shariati Ave, Mojtabae St, Kavian Street, 41, Tehran, Iran. P.O. Box 15875-4416.



**Dr. Farhang Honarvar**

Professor

Mechanical Engineering department

**Email:** [honarvar@kntu.ac.ir](mailto:honarvar@kntu.ac.ir)

**Phone No:** +98 2184063247

**Fax:** +98 2188674748

**Personal website:** <https://wp.kntu.ac.ir/honarvar/>

**Education:**

**B.Sc.:** Mechanical Engineering, University of Tehran - Iran, 1988.

**M.Sc.:** Mechanical Engineering, University of Waterloo – Canada, 1993.

**Ph.D.:** Mechanical Engineering, University of Toronto – Canada, 1997.

**Research interests:**

- Ultrasonic nondestructive evaluation of materials
- Signal processing of ultrasonic NDE signals
- Elastic and acoustic wave propagation and scattering
- Measurement Systems

**Academic/Industrial Career:**

- Management and supervision of ultrasonic nondestructive testing project
- Iranian Society for Nondestructive Testing chair.
- Member of Iranian Society of Acoustics and Vibration (ISAV).
- Managing director of Nasir Journal of Science and Engineering.

**Office Address:**

Mechanical Engineering department, Faculty of Mechanical Engineering, Vanak Square, Molla-Sadra, Pardis Box 19395-1999Tehran, Iran.



**Dr. Faramarz Hossein babaei**

Professor

Electrical Engineering department

**Email:** fhababaei@kntu.ac.ir

**Phone No:** +98-21 84062411 (Room)

**Fax:** +982188768289

**Personal website:** <http://wp.kntu.ac.ir/fhababaei>

**Education:**

**B.Sc.:** Electrical Engineering, Imperial College, London University, UK (1978)

**M.Sc.:** Materials Sc., Imperial College, London University, UK (1975)

**Ph.D.:** Electrical Engineering, Amirkabir Industrial University, Tehran, Iran (1971)

**Research interests:**

- High temperature systems
- electroceramic devices
- electrophoresis and electrophoretic deposition
- gas sensors and e-nose

**Academic/Industrial Career:**

- Founder and Head, Electronic Materials Laboratory, Faculty of Electrical Engineering, K.N. Toosi University of Technology; since 1983.
- Adjunct Professor, Materials Science Engineering Department, Faculty of Applied Science, UBC ([www.ubc.ca](http://www.ubc.ca)), Vancouver, Canada; 2003-2008.
- Cofounder and Member of the Board, Industrial Control Center of Excellence, Tehran, Iran.
- Founder and Chairman of the Board, Exciton Co. Ltd., ([www.exciton.ir](http://www.exciton.ir)); since 1979
- Founder and Chairman of the Board, ManzoomehSanat Co. Ltd.; since 1985.
- Founder and Chairman of the Board, HezarehSevom Co. Ltd.; ([www.hezare-sevom.ir](http://www.hezare-sevom.ir)); since 1998.
- Founder and Chairman of the Board, Iran-Magnatis Co. Ltd. (The first producer of permanent magnets in Iran); 1978-1994
- Co-founder and Member of the Board, Iranian Ceramic Society; 1989-2000
- R&D task team management

**Office Address:**

Faculty of Electrical Eng., K.N. Toosi University of Technology (KNTU), Sayyed Khandan, P.O. Box: 16315-1355, Tehran, Iran.





**Dr. Mohammad Karimi**

Assistant Professor

GIS Department

Geodesy & Geomatics Faculty

**Email:** mkarimi@kntu.ac.ir

**Phone No:** +98 2188786212

**Fax:** + 98 2188786213

**Personal website:** <https://wp.kntu.ac.ir/mkarimi/>

**Education:**

**B.Sc.:** Surveying Engineering, Tehran University, Tehran, Iran, 1996-2000.

**M.Sc.:** Geomatics Engineering, GIS, K.N. Toosi University of Technology, Tehran, Iran, 2000-2002.

**Ph.D.:** Geomatics Engineering, GIS, K.N. Toosi University of Technology, Tehran, Iran, 2005-2010.

**Research interests:**

- GIS
- land use planning
- spatial planning support system
- potential mapping

**Academic/Industrial Career:**

- Research Affairs Manager of K.N.Toosi of university

**Office Address:**

Faculty of Geodesy & Geomatics Engineering, K. N. Toosi University of Technology, No. 1346, Vali-asr Ave, Mirdamad Cross, P.O.Box: 15875-4416 Tehran, Iran.

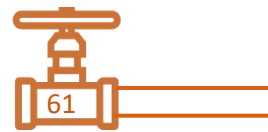

**Dr. Ali Khaki-Sedigh**

Professor

Control & Systems Department  
Faculty of Electrical Engineering

**Email:** [sedigh@kntu.ac.ir](mailto:sedigh@kntu.ac.ir)

**Phone No:** +98 21 84062317

**Fax:** +98 21 88462066

**Personal website:** <https://wp.kntu.ac.ir/sedigh/>

**Education:**

**B.Sc.:** Single Honors Mathematics, University of Newcastle Upon Tyne, England, 1983.

**M.Sc.:** Control System, UMIST, England, 1985.

**Ph.D.:** Control Engineering, University of Salford, England, 1988.

**Research interests:**

- Robust multivariable and Adaptive Control Theory
- Intelligent Control (Genetic Design and Neural Networks)
- Industrial applications of control systems
- Predictability and prediction of system's behavior
- History of Control
- Control loop performance monitoring

**Academic/Industrial Career:**

- President of K.N. Toosi University of Technology (KNTU), 2003-8, 2013-current
- Head of Electrical Engineering Department 1990-1992 and 1998-1999.
- Visiting Professor in the University of Bremen, Germany, June-July 2000 & July-August 2002.
- Distinguished Professor award, The Academy of Sciences of Iran, 2012
- Distinguished Professor award, IEEE Iran Section, 2014

**Office Address:**

Faculty of Electrical Eng., K.N. Toosi University of Technology (KNTU), Sayyed Khandan, P.O. Box: 16315-1355, Tehran, Iran.

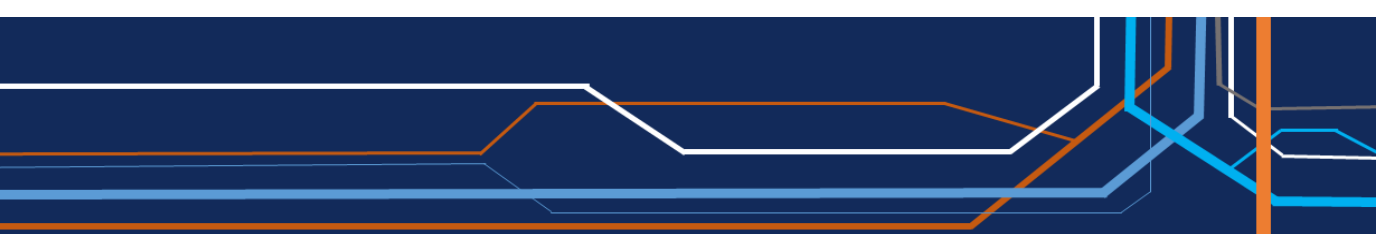



**Dr. Afshin Khoshand**

Assistant Professor  
Civil Engineering Department

**Email:** khoshand@kntu.ac.ir

**Phone No:** +98 21 88770006

**Education:**

**B.Sc.:** Civil Engineering, Semnan University, Semnan, Iran, 2003-2007.

**M.Sc.:** Civil Engineering, K. N. Toosi of Technology, Tehran, Iran, 2007-2009.

**Ph.D.:** Civil Engineering, Ottawa University, Ottawa, Canada, 2010-2014.

**Academic/Industrial Career:**

- Supervised and managed geotechnical site investigation and field tests.
- Conducted geotechnical analysis (stability, stress, and deformation of soil structures)
- Trained and supervised technicians and internship students.

**Office Address:**

Civil Engineering Faculty K.N. Toosi University of Technology No. 1346, Vali Asr Ave., Mirdamad Cross, P.O. Box: 19967-15433, Tehran, Iran.

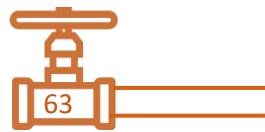

**Dr. Keivan Kiani**

Assistant Professor  
Civil Engineering Department

**Email:** [k\\_kiani@kntu.ac.ir](mailto:k_kiani@kntu.ac.ir)

**Phone No:** +98 21 88779473

**Fax:** +98 21 88779476

**Personal website:** [https://wp.kntu.ac.ir/k\\_kiani/](https://wp.kntu.ac.ir/k_kiani/)

**Education:**

**B.Sc.:** Department of Civil Engineering, Isfahan University of Technology, Isfahan, Iran, 1995-1999.

**M.Sc.:** Department of Civil Engineering, Sharif University of Technology, Tehran, Iran, 1999-2001.

**Ph.D.:** Department of Civil Engineering, Sharif University of Technology, Tehran, Iran, 2002-2010.

**Research interests:**

- Vibrations of macro-structures due to moving masses
- Nonlocal continuum-based modeling of nanostructures
- Dynamic interactions between moving nanoparticles and nanoscaled tubes and plates
- Nanofluidic flow-induced vibrations in carbon nanotubes

**Academic/Industrial Career:**

- Lead contractor for three scientific projects of INSF since 2010.

**Office Address:**

Civil Engineering Faculty K.N. Toosi University of Technology No. 1346, Vali Asr Ave., Mirdamad Cross, P.O. Box: 15875-4416 Tehran, Iran.



**Dr. Amirhossein Nikoofard**

Assistant Professor

Control & Systems Department

Faculty of Electrical Engineering

**Email:** [A.nikoofard@kntu.ac.ir](mailto:A.nikoofard@kntu.ac.ir)

**Phone No:** +98-21-84062209

**Personal website:** <https://wp.kntu.ac.ir/a.nikoofard>

**Education:**

**B.Sc.:** Electrical Engineering (Control systems) School of Electrical and Computer Engineering University of Tehran, Tehran, Iran, 2004- 2008.

**M.Sc.:** Electrical Engineering (Control systems) School of Electrical and Computer Engineering University of Tehran, Tehran, Iran, 2008- 2011.

**Ph.D.:** Electrical Engineering (Control systems) Department of Engineering Cybernetics Norwegian University of Science and Technology (NTNU), 2012- 2016.

**Research interests:**

- Nonlinear state estimation and system identification,
- Model Predictive Control, Adaptive Control, and Optimization
- Automatic solutions for Oil and Gas industry
- Drilling, Production, Reservoir management,
- Game theory
- Soft computing, such as fuzzy logic, neural networks, and evolutionary algorithms

**Academic/Industrial Career:**

- Norwegian University of Science and Technology, Trondheim, Norway, 2012-2016 (Researcher)
- Arad Aluminum Construction Engineering, Tehran, Iran, 2011 -2012.
- Iran -Khodro Company, Tehran, Iran, June 2007 -September 2007.

**Office Address:**

Faculty of Electrical Eng., K.N. Toosi University of Technology (KNTU), Sayyed Khandan, P.O. Box: 16315 1355, Tehran, Iran.



**Dr. Sorour Ramezani-pour**

Assistant Professor

Faculty of Chemistry

**Email:** Ramezani-pour@kntu.ac.ir

**Phone No:** +98 21 2306422

**Fax:** +98 21 22853650

**Personal website:** <http://wp.kntu.ac.ir/ramezani-pour>

**Education:**

**B.Sc.:** Pure Chemistry, Imam Khomeini International University, Qazvin, Iran, 1998-2002.

**M.Sc.:** organic chemistry, K.N. Toosi University of Technology, Tehran, Iran, 2004-2006.

**Ph.D.:** organic chemistry, K.N. Toosi University of Technology, Tehran, Iran, 2009-2013.

**Research interests:**

- Synthesis & Purification of some Pharmaceutical (active pharmaceutical ingredient) and another Organic compounds.

**Academic/Industrial Career:**

- Medicinal chemistry

**Office Address:**

Department of Chemistry K. N. Toosi University of Technology P.O. Box: 16315-1618 Tehran, Iran.



**Dr. Saeed Rayati**

Professor of Chemistry  
Chemistry Department

**Email:** rayati@kntu.ac.ir

**Phone No:** +98 21 23064221

**Fax:** +98 21 22853650

**Personal website:** <https://wp.kntu.ac.ir/rayati/>

**Education:**

**B.Sc.:** Pure Chemistry, Zanjan, Iran, 1991-1995.

**M.Sc.:** Inorganic Chemistry, Buo-Ali Sina University, Hamadan, Iran. 1995-1998.

**Ph.D.:** Inorganic Chemistry, Shiraz University, Shiraz, Iran, 1998-2003.

**Research interests:**

- Catalysis and biocatalysis: catalytic oxidation of organic compounds in the presence of synthetic metalloporphyrins as model for reactions of cytochrome P-450.
- Material chemistry, Nanocomposite Materials and Nanoparticles
- Nano chemistry and nano catalysts
- Using of metalloporphyrin complexes as chain transfer catalyst in radical polymerization of alkenes.
- Novel metal complexes of symmetrical and non-symmetrical tetradentate Schiff Bases are designed and synthesized.
- Probing the use of new transition metal complexes of Schiff base ligands with a view of creating catalytic of broad applicability

**Office Address:**

Department of Chemistry, K.N. Toosi University of Technology, P.O. Box 16315-1618, Tehran 15418, Iran.



**Dr. Mahmoud Samadpour**

Associate Professor

Physics department

**Email:** samadpour@kntu.ac.ir

**Phone No:** +98 21 23064306

**Fax:** +98 21 23064218

**Personal website:** <http://wp.kntu.ac.ir/samadpour>

**Education:**

**B.Sc.:** Physics, Kharazmi University, Tehran, Iran, 2001-2005.

**M.Sc.:** Physics, Sharif University of Technology, Tehran, Iran, 2005-2007.

**Ph.D.:** Nanotechnology, Sharif University of Technology, Tehran, Iran, 2007-2011.

**Research interests:**

- Nanostructured energy devices,
- Super hydrophobic surfaces,
- Super absorbers for oil and organic contamination

**Office Address:**

Physics department, Faculty of Science, K.N. Toosi University of Technology, Shariati Ave, Mojtabae St, Kavian Street, 41, Tehran, Iran. P.O. Box 15875-4416.







**Dr. Sadegh Seddighi**

Assistant Professor

Thermo-Fluid Engineering

Department of Mechanical Engineering

**Email:** sadegh.seddighi@kntu.ac.ir

**Phone No:** +98 21 84063253

**Fax:** +98 21 88674748

**Personal website:** <http://www.sadeghseddighi.ir/>

**Education:**

**B.Sc.:** Sharif University of Technology, Mechanical Engineering, Tehran, Iran, 1996-2000.

**M.Sc.:** Royal Institute of Technology, Mechanical Engineering, Sweden, 2007-2009.

**Ph.D.:** Chalmers University of Technology, Energy and Environment, Sweden, 2009-2014.

**Research interests:**

- Energy
- Environment

**Academic/Industrial Career:**

- K.N. Toosi University of Technology, Assistant Professor of Mechanical Engineering (2014-now)
- Valmet Energy, Sweden & Finland, Research Scientist (2009-2014)
- Chalmers University of Technology, Sweden, Researcher (2009-2014)
- Petropars Ltd., Iran, Field Engineer, Phases 6-8 SP Gas Field Development (2004-2007)
- Civil Services, Iran (2003-2004)
- Railway Research Center, Iran, Mechanical Engineer at Locomotive group (2002-2003)
- Hydro Aerodynamic Laboratory, Iran, Mechanical Engineer (2001-2002)

**Office Address:**

Department of Mechanical Engineering, K.N. Toosi University of Technology, Pardis Avenue, Mollasadra Avenue, Tehran, Iran.



**Dr. Shahram Seidi**

Assistant Professor

Faculty of Chemistry

Email: [s.seidi@kntu.ac.ir](mailto:s.seidi@kntu.ac.ir)

Phone No: +98 21 23064228

Fax: +98 21 22853650

Personal website: <http://wp.kntu.ac.ir/seidi>

**Education:**

**B.Sc.:** Applied chemistry, Arak University, Arak, Iran, 2002-2006.

**M.Sc.:** Analytical chemistry, Shahid Beheshti University, Tehran, Iran, 2006-2008.

**Ph.D.:** Analytical chemistry Tarbiat Modares University, Tehran, Iran, 2008-2012.

**Research interests:**

- Extraction and microextraction techniques (sample preparation)
- Pharmaceutical and Biomedical analysis
- Forensic and Narcotic Science
- Atomic Spectroscopy
- Separation Science (GC, HPLC), Lab on a Chip
- Environmental monitoring and pollution research
- Trace metal analysis
- Soil analysis
- Water analysis
- Air analysis

**Academic/Industrial Career:**

- Assistant Professor of Analytical Chemistry; Research Associate of Faculty of Chemistry
- Member of the Committee on Supplying Equipment and Chemicals of the Iranian Chemical Society

**Office Address:**

Department of Chemistry, K. N. Toosi University of Technology P.O. Box: 16315-1618 Tehran, Iran.

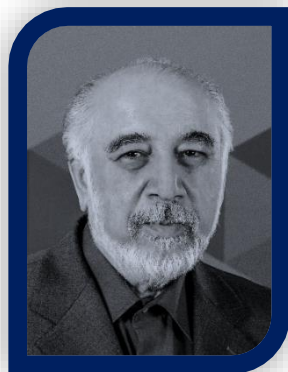

**Dr. Abbas Sha'ri Moghaddam**

**Email:** abbas.shaari@gmail.com

**Phone No:** +98 21 88209878

**Fax:** +98 21 88193878

#### **Education:**

**B.Sc. & M.Sc.:** B.Sc. & M.Sc.: Electronics Engineering, Amir Kabir University of Technology, Tehran, Iran, 1966.

#### **Academic/Industrial Career:**

- Board Member of 4 private companies
- named: Rampco group, Spec, Pidemco, Sana Group. (present)
- Member of trustee Board of 4 universities named: Shiraz, Amirkabir, Elmi Karbordi, Fanni Herfehee. (present), Board Member or Inspector of 3 NGOs named: Iran Management Association, Iranian Society of Instrument & Control Engineers., Iranian Association of Industry & University Relation Development. (present)
- Board Member and vice chairman of NPC (National Petrochemical Co.) (2016)
- Deputy Minister of Oil in charge of Petrochemical and MD of NPC (2013-2016)
- Assistant Managing Director of Nebco (2011-2013)
- Managing Director of Arya "Sasol Polymer Company". (2008-2011)
- Managing Director of Bakhtar Petrochemical Company. (2006-2008)
- Chairman of the Board of Directors and Managing Director of BIPC. (1994-2006)
- Executive Board Member of NPC, acting as: Technical & Operation Director. (1983-1994)
- As, Line Manager & Middle Manager in Elec.& Instrument Maintenance Dept. and Technical services Division in Shiraz Petrochemical Co. (1966-1983).

#### **Office Address:**

Rampco Group, # 50, Bahrami St., Before Niayesh junction, Vali-Asr Ave., Tehran, Iran.

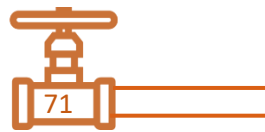

**Dr. Hamid R. Taghirad**

Professor

Control & Systems Department  
Faculty of Electrical Engineering

**Email:** Taghirad@kntu.ac.ir

**Phone No:** + 98 21 8406 2321

**Fax:** + 98 21 8846 2066

**Personal website:** aras.kntu.ac.ir

**Education:**

**B.Sc.:** Sharif University of Technology, Tehran, Iran, 1989.

**M.Sc.:** Control Engineering, McGill University, Montreal, 1993.

**Ph.D.:** Control Engineering, McGill University, Montreal, 1997.

**Research interests:**

- Intelligent Pig
- Autonomous Robotics
- Surgical Robotics
- Parallel and Cable robotics
- Dynamical Systems and Control
- Industrial Robotics and Automation

**Academic/Industrial Career:**

- Ministry of SRT, Department of Educational Planning , Head of Multidisciplinary Group
- K. N. Toosi U. of Tech., Member of Auditorial Board
- Faculty of Electrical Engineering, Dean
- International Conference on Robotics and Mechatronics, Member of the steering committee
- IEEE Control System Group Chair, Iran Section
- IEEE Senior member of Control System, and Robotics and Automation Societies
- Industrial Control Center of Excellence, K. N. Toosi U. of Tech. Member of the board
- Robotics Society of Iran, Tehran, Member of the board
- International Journal of Robotics, Editorial board
- Mechatronics Magazine, Editor in Chief
- Iranian Society of Mechatronics, Tehran, Vice President and member of the board K.N. Toosi U. of Tech, Tehran, Director of the Office of International Scientific Cooperation (OISC)
- McGill University, Center for Intelligent Machines, Montreal, Visiting Professor
- Iranian Society of Mechatronics, Tehran, Member of the board K.N. Toosi U. of Tech, Tehran, Director of the Department of Systems and Control K.N. Toosi U. of Tech, Tehran, Professor.
- Advanced Robotics and Automated Systems (ARAS), Director of Electrical Engineering Dept.

**Office Address:**

Faculty of Electrical Eng., K.N. Toosi University of Technology (KNTU), Sayyed Khandan, P.O. Box: 16315-1355, Tehran, Iran.



**Dr. Mohammad Taleai**

Associate Professor  
Geodesy & Geomatics Faculty

**Email:** taleai@kntu.ac.ir

**Phone No:** +98 21 8878 6212

**Fax:** + 98 21 8878 6213

**Personal website:** <https://wp.kntu.ac.ir/taleai/>

**Education:**

**B.Sc.:** Surveying Engineering, Tehran University, Tehran, Iran, 1994-1998.

**M.Sc.:** Geomatics Engineering, K.N.Toosi University of Technology, Tehran, Iran, 1998-2000.

**Ph.D.:** Geomatics Engineering, K.N.Toosi University of Technology, Tehran, Iran, 2000-2007.

**Research interests:**

- Public Participation GIS (PPGIS)
- User-Generated Content and Volunteered geographic information (VGI)
- Spatial planning support system (SPSS)
- GIS-based planning and management
- Multi-Objectives and evolutionary algorithms
- 3D GIS & Smart City

**Academic/Industrial Career:**

- He is a member of Iranian center of excellence in geospatial information technology. Since 2000, he has been a member of Geo-Spatial Information Technology (GIT) research team and worked on several GIS projects in various fields. He has published more than 130 papers in scientific journals and conferences. He is also a member of the editorial board of several scientific journals and organized a set of conferences.

**Office Address:**

Faculty of Geodesy & Geomatics Engineering, K. N. Toosi University of Technology, No. 1346, Vali-asr Ave, Mirdamad Cross, P.O. Box: 15875-4416, Tehran, Iran.

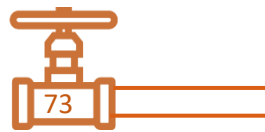

**Dr. Babak Tavassoli**

Assistant Professor  
Control & Systems Department  
Faculty of Electrical Engineering

**Email:** [tavassoli@kntu.ac.ir](mailto:tavassoli@kntu.ac.ir)

**Phone No:** +982184062408

**Fax:** +98 21 88462066

**Personal website:** <http://wp.kntu.ac.ir/tavassoli/>

**Education:**

**B.Sc.:** Electrical Engineering, University of Tehran, Tehran, Iran, 1994 -1998.

**M.Sc.:** Control Engineering, University of Tehran, Tehran, Iran, 1998 – 2000.

**Ph.D.:** Control Engineering, University of Tehran, Tehran, Iran, 2003 -2009.

**Research interests:**

- Control systems
- Automation systems
- Networked systems
- Hybrid systems

**Academic/Industrial Career:**

- Researcher at the Research institute of Petroleum Industry (2009-2010).
- Head of the process control algorithms group at Farineh Fanavar. Co. (2003-2008).

**Office Address:**

Faculty of Electrical Eng., K.N. Toosi University of Technology (KNTU), Sayyed Khandan, P.O. Box: 16315-1355, Tehran, Iran.



**Dr. Mohammad Teshnehlab**

Professor

Control & Systems Department  
Faculty of Electrical Engineering

**Email:** Teshnehlab@kntu.ac.ir

**Phone No:** +98 21 84062316

**Personal website:** <https://wp.kntu.ac.ir/teshnehlab/>

**Education:**

**B.Sc.:** Electrical Engineering, Stony Brook University, NY, USA, 1981.

**M.Sc.:** Electrical Engineering, Oita University, Japan, 1991.

**Ph.D.:** Doctor of Philosophy, Saga University, Japan, 1993.

**Research interests:**

- Artificial Rough and Deep Neural Networks
- Fuzzy Systems and Neural Nets.
- Optimization and its applications in identification, prediction, classification and Control

**Academic/Industrial Career:**

- Member of Industrial Control Center of Excellence and founder of Intelligent Systems Laboratory (ISLab).
- Head and Co-founder of Intelligent Systems Scientific Society of Iran (ISSSI)
- Member of editorial board of International Journal of Information & Communication Technology Research (IJICTR).

**Office Address:**

Faculty of Electrical Eng., K.N. Toosi University of Technology (KNTU), Sayyed Khandan, P.O. Box: 16315 1355, Tehran, Iran.





**Dr. Mohammad Javad Valadan Zoej**

Professor

Geodesy & Geomatics Faculty

**Email:** valadanzouj@kntu.ac.ir

**Phone No:** +98 21 878 6212

**Fax:** + 98 21 878 6213

**Personal website:** <https://wp.kntu.ac.ir/valadanzouj/>

#### Education:

**B.Sc.:** Geomatics Engineering, K. N. Toosi University of Technology, Tehran, Iran, 1984-1988.

**M.Sc.:** Geomatics Engineering, Geomatics Science, University Laval, Quebec, Canada, 1991-1993.

**Ph.D.:** Geomatics Engineering, Photogrammetry and Remote Sensing, University of Glasgow, Glasgow, UK, 1993-1997.

#### Research interests:

- Hyperspectral imaging
- Information Extraction from images

#### Academic/Industrial Career:

- Director of an 18 months' project entitled: Design and establishment of Iranian National Spectral Library, ISA, Iran. (2012-2014)
- Director of a 6 years' project entitled: Designing, establishing and setting up of National Remote Sensing Laboratory, ISA, Iran. (2008-2014)
- Director of a 12 months' project entitled: Design of a Site for Geometric and Radiometric Calibration of Imaging Sensors, NCC, Iran. (2012-2013)
- Director of a 12 months' project entitled: Development of National Iranian Copper Industries GIS, National Iranian Copper Industries Company, Tehran, Iran. (2010-2011)
- Director of a 12 months' project entitled: Development of Tavanir GIS (2), Ministry of Energy, KNTU, Tehran, Iran. (2010-2011)
- Director of a 9 months' project entitled: Strategic and Action Planning of GIS & Organizational SDI for Ministry of Communication and Information Technology, MCIT, KNTU, Tehran, Iran. (2008-2009)
- Director of a 12 months' project entitled: Design and Implementation of a Software for Management and Presentation of the Satellite Images of Iranian Space Agency, ISA, KNTU, Tehran, Iran. (2007-2008)

#### Office Address:

Faculty of Geodesy & Geomatics Engineering, K. N. Toosi University of Technology, No. 1346, Vali-asr Ave, Mirdamad Cross, P.O.Box: 19395-4941, Tehran, Iran.



**Dr. Masoud Ziabasharhagh**

Professor

Faculty of Mechanical Engineering

**Email:** [mzia@kntu.ac.ir](mailto:mzia@kntu.ac.ir)

**Phone No:** +98 21 8406 3242

**Fax:** +98 21 8867 7274

**Personal website:** <https://wp.kntu.ac.ir/mzia/>

**Education:**

**B.Sc.:** Mechanical Engineering, K. N. Toosi University of Technology, Tehran, Iran, 1984.

**M.Sc.:** Mechanical Engineering, Birmingham University, U.K, 1988.

**Ph.D.:** Mechanical Engineering Cranfield University, U.K, June 1992.

**Research interests:**

- Energy conversion
- Turbomachinery

**Office Address:**

Faculty of Mechanical Engineering of K. N. Toosi University of Technology, Vanak Square, Molla-Sadra, Pardis P. O. Box: 19395-1999, Tehran, Iran.

## K. N. Toosi University of Technology

is a public, higher educational institution in Tehran, Iran. The university was founded in 1928. With more than 300 full-time faculty members and 7200 students, K. N. Toosi University of technology is known for its excellent track record of research activities and industrial projects. K. N. Toosi University of Technology is committed to being an internationally recognized university by advancing knowledge through research and educating students in science, technology, and other areas of scholarship that will best serve the country and the world. K. N. Toosi University of Technology is determined to provide its students, faculty, and staff with the best possible resources and conditions for learning and research, and to create a respectful and nurturing, yet challenging work environment. It will cooperate with the community, other educational institutions, and the industry to discover and apply new knowledge and technologies. It is committed to preparing its students for fulfilling careers and improving the quality of life through leading-edge research and unrelenting innovation.



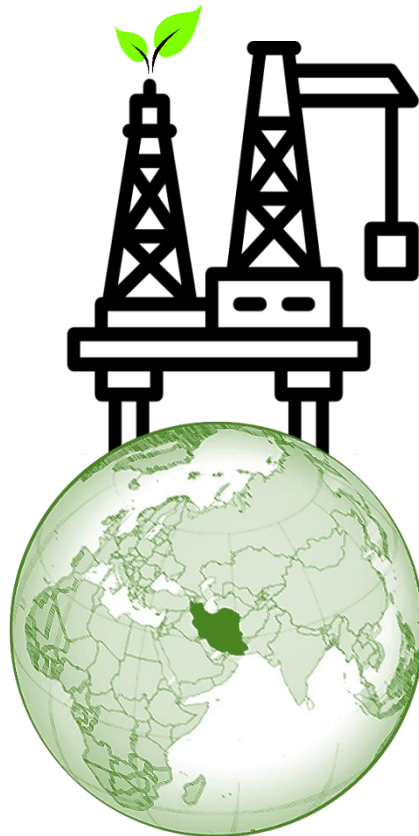

[www.PIPRC.kntu.ac.ir](http://www.PIPRC.kntu.ac.ir)

**PIPRC** Petroleum Industry Productivity Research Center

K.N. Toosi University of Technology.

Iran, Tehran Province, Tehran, Mirdamad Blvd, No. 470

Tel: +98(21)88881002, Fax: +98(21)88462066